

Model AY70-2
FOX 70
Service Manual



Instruction

This manual contains detailed information for AY70-2 (ATV), maintenance, adjustments, disassembly, installation, inspection points and specifications

Please read the manual carefully and follow the instructions closely when performing inspections and repairs, this will increase the reliability, performance and overall lifespan of the vehicle.

Contents

Chapter 1 Maintenance information

Chapter 2 Plastics and Body parts

Chapter 3 Regular Maintenance and adjustment

Chapter 4 Outer parts of engine

Chapter 5 Engine internals

Appendix Electrical schematic diagram

All contents in this manual are subject to improvement and update without notice.

ZHEJIANG KAYO MOTOR CO., LTD.

Conversion table

Item	Unit conversion
pressure	1kgf/cm ² =98.0665kPa; 1kPa=1000Pa
	1PSI=0.0689kgf/cm ²
	1mmHg=133.322Pa=0.133322kPa
Torque	1kgf·m=9.80665N·m
volume	1mL=1cm ³ =1cc
	1L=1000cm ³
Moment	1kgf=9.80665N
Length	1in=25.4mm

Danger/warning/attention

Take the below explanations seriously, it's important for maintenance, especially important during engine maintenance.

Danger: Be on high alert for danger.

Warn: Be on alert for moderate danger.

Attention: Be on alert for minor danger.

This manual may contain some potential risks when performing engine work and maintenance, Please pay close attention to the above explanations, Service technician or mechanics should have basic mechanical knowledge before performing any service, maintenance, or inspection.

Service Information

- 1.1 Warnings
- 1.2 VIN Number
- 1.3 Main parameters list
- 1.4 Maintenance parameters list
- 1.5 Torque tightening
- 1.6 Lubricant, sealant
- 1.7 Cable, hose and wiring diagram

1.1 Safety precautions

Safety first

1. Wearing work clothes (coveralls), hat and safety boots suitable for the operation. In some conditions safety glasses, dust masks, gloves and other safety protective supplies are needed to protect you from injury.
2. Do not run the engine in unventilated places.
3. To prevent burns, do not touch the engine or exhaust until cooled.
4. Battery solution (dilute sulfuric acid) is a strong corrosive agent; contact with the skin, contact with eyes may cause blindness. If the battery solution accidentally touches clothes or skin, rinse immediately with clean cold water. If the battery solution is touches eyes, please flush immediately with plenty clean cold water and get medical treatment as soon as possible. Battery and battery solution should be kept out of reach of children. Battery charging will produce flammable and explosive gases, if exposed to a source of fire or spark there is a risk of explosion or fire. Please charge in well-ventilated places.
5. As gasoline is flammable and explosive. Pay attention to sparks as well as open flames. Vaporized gasoline may explode if exposed to open flame or sprks , please choose well-ventilated areas away form these hazards when refueling.
6. Attention, the rear wheel, clutch or other rotating parts and movable parts may clip hands and clothes during maintenance.
7. Two or more people must constantly greet each other when operating to ensure safety.

Disassembly and installation instructions

ZHEJIANG KAYO MOTOR CO., LTD.

1. All the Parts, lubricants oils and fluids must be Kayo brand parts or Kayo recommends.
2. During disassembly, Please sort and separate out the parts and fasteners of each system to ensure that everything is put back together properly.
3. Clean the vehicle or parts to be serviced before inspection.
4. The Gasket, o-ring, piston pin baffle ring, cotter pin and other onetime use parts must be replaced after disassembling.
5. Snap rings can be deformed if opened too much during disassembly. DO NOT re-use deformed snap rings.
6. After disassembly and inspection, clean the parts and blow the cleaning agent away with compressed air before measurement. Grease the moving surface before assembly.
7. During disassembly, check all the necessary specifications and measure according to directions in this manual. Make sure measurements and conditions are within specification.
8. Bolts, nuts, screws and other fasteners shall be pre-tightened and then tightened in accordance with the specified tightening torque in a diagonal sequence. From large to small, and from inside to outside.
9. Inspect all rubber parts during disassembly and replace if necessary. In addition, as some rubber pieces are not resistant to corrosive materials, please keep them from contacting volatile oils, grease, or liquids.
10. Smear or inject recommended grease in specific places as service manual.
11. Use special tools for disassembly and installation.
12. Ball bearings can be rotated with finger to confirm whether the rotation is flexible and smooth. If there are problems as below, please replace bearing.
 - Bearing axial and radial clearance is oversized.
 - Clean and grease bearings with a tight spots when rotated. If the bearings still feel stuck after cleaning, replace. If it can't be cleaned, replace it.
 - If the bearing is a press fit, and becomes deformed after disassembling, replace it.
13. Bearings should be lubricated or packed with grease before assembly. Take note of the direction of installation when assembling. When installing open or double-sided dustproof

bearing, make the manufacturer's logo and dimensions outwards.

14. Let the chamfered side towards force direction when install the Snap-ring. Do not use the rings without elasticity. After assembly, rotate the Snap-ring to confirm that it is firmly installed in the slot.

15. It's important to check that all fastening parts are tightened and that functions are normal after assembling.

16. Brake fluid and coolant can damage surfaces, painted parts, plastic parts, rubber parts, etc., do not let brake fluid contact to these parts, If brake fluid contacts these parts rinse and dilute with water immediately.

17. When installing oil seals manufacturer's mark and sizes face outward.

- Check the oil seal before using.
- Pay attention not to make oil seal lip curly, do not let burr scratch oil seal lip during assembly.
- Grease the oil seal lip before assembly.

18. When installing rubber hose parts, insert the rubber pipe into the fitting. If there is a hose clamp, install the hose clamp in the hose indentation. Replace rubber hoses if dried, cracked, or deformed.

19. Keep the inner of engine and brake hydraulic system away from dust and clay.

20. Clean all gasket material from surfaces of before installing new parts or reassembling.

21. Do not bend the cable excessively. Kinked or damaged cables may cause poor response and inner cables to fray and eventually break.

22. When assembling any protective caps, covers or boots make sure they are seated correctly in the respective grooves.

Engine Break-in

There is a lot of relative motion components in engine, such as piston, piston ring, cylinder, mutually meshing gear, etc., it's very important to have a standard break-in at the beginning of using. Break-in can help the moving parts adapt to each other, correction work, form a

ZHEJIANG KAYO MOTOR CO., LTD.

smooth friction surface which can bear heavy load, by this way the engine will have excellent performance and reliability.

Recommended break-in time is 20 hours, as follows:

0~10 hours: Operate at no more than ½ throttle, keep gear changes and speed variances to a minimum. Do not operate for extended amounts of time with a fixed throttle position. Let the engine cool for 5 to 10 minutes after each hour of operation. Avoid quick acceleration.

0~20 hours: Operate at no more than ¾ throttle, Do not operate for extended amounts of time with a fixed throttle position. Change gears and vary speeds as necessary. Let the engine cool for 5 to 10 minutes after each hour of operation. Avoid quick acceleration

Note:

- During break-in period, inspect for noises and wear and follow maintenance schedule.
- After Break-in period is complete schedule the unit for an inspection and service.

1.2 VIN Number

Model	AY70-2
VIN number	
Engine number	

①VIN number

③Engine number

②Nameplate

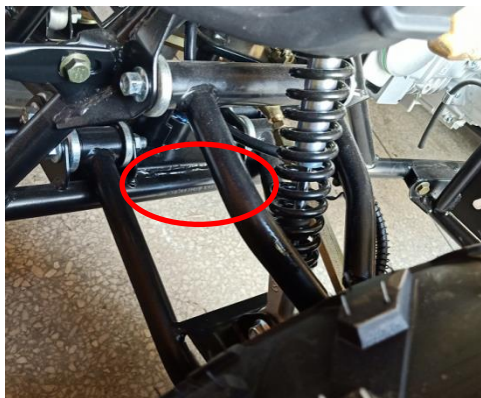

1 VIN Number Frame stamp



2 Engine number

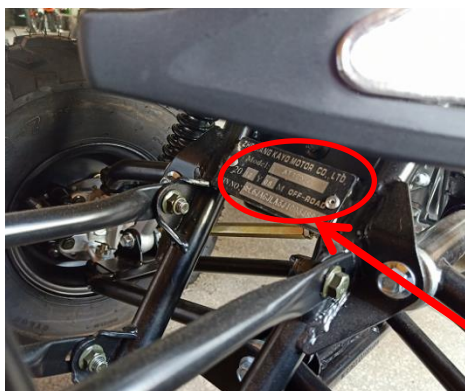

3 VIN/ Nameplate

1.4 Specifications, Model information

No.	Item	
1	Brand	KAYO
2	Type	AY70-2
3	Name	70cc utility ATV
4	Company	ZHEJIANG KAYO MOTOR CO., LTD.

● Dimensions, Vehicle Specifications

1	Dimension (L*W*H) (mm)	1230*800*870
2	Handlebar height (mm)	870
3	Handlebar width (mm)	800
4	Rear height (mm)	650
5	Ground clearance of seat (mm)	635
6	Min. terrain clearance (mm)	85
7	Wheelbase (mm)	900
8	Front track (mm)	640
9	Rear track (mm)	550
10	Turning radius (mm)	1650
11	Turning angle (degree)	38° ± 2°

ZHEJIANG KAYO MOTOR CO., LTD.

12	Net weight (Kg)	76±2
13	Kerb weight (battery+fuel) (Kg)	81
14	Max. Speed Km/h	40 (limited speed)

● Engine parameters

No.	Item	
1	Starting type	Electric
2	Type	horizontal, Single cylinder, four stroke, oil cooling
3	Distribution way	SOHC/chain drive
4	Cylinder diameter × mileage (mm)	47*41.4
5	Compression ratio	8.8 :1
6	Lubrication mode	Combination splash and pressure feed
7	Oil pump type	Rotor
8	Lubricating oil filter type	All-flow filter, paper filter
9	Oil trademark	SAE15W-40
10	Cooling type	Air cooling
11	Cooling fluid	/
12	Air filter type	Filter with sponge filter element
13	Carburetor	Horizontal plunger type (Jingke PZ19/EPA state)
14	Tank volume	2L
15	Clutch type	Dry automatic clutch

ZHEJIANG KAYO MOTOR CO., LTD.

16	Gearshift method	CVT		
17	Gear range	CVT without reverse gear		
18	Shift type	R~N~D		
19	Reduction ratio		Forward gear D	Reverse gear R
		Primary	Gear hub of clutch/primary gear	
		Single-stage	Gear ratio of forward gear	Gear ratio of forward gear
		Overall		
● Frame				
20	Drive sprocket ratio	37/13		
21	Output type	Chain drive, rear wheel drive		
22	Brake type	Front and rear disc		
23	Suspension type	Freestanding double rocker		
24	Frame type	Steel tube and steel plate welded type		

● Lubrication system

Item	Standard	Limitatio	
Engine oil capacity	Change oil	800mL (No oil filter element replaced)	—
	Change oil	800mL (replace the oil filter element)	
	Full capacity	800mL	—
Recommended engine oil (original)		<ul style="list-style-type: none"> • four-strokes motorcycles SAE-15W-40 <p>For replacements, it must be within following scope:</p> <ul style="list-style-type: none"> • API classification: SG or upper grade engine oil • SAE specification: refer to left table 	
	Radial clearance of inner	0.07 mm~0.15mm	0.2mm
	Radial clearance between	0.03 mm~0.10mm	0.12mm

ZHEJIANG KAYO MOTOR CO., LTD.

Oil pump rotor	Axial clearance between	0.023 mm ~0.055 mm	0.12 mm
	Oil pressure	1500r/min , 90°C: 200 kPa ~400kPa, General 240 kPa 6000r/min , 90°C:600 kPa ~700kPa,	

● **Air intake system (see engine section)**

● **Cooling device (without)**

● **Wheel (front and rear wheels)**

Item		Standard	Limitation
Rim jump	Vertical	1.0mm	2.0mm
	Horizontal	1.0mm	1.8mm
Tire	Residual groove	~	3.0mm
	Air pressure	4.0 PSI	~

● **Brake system**

Item		Standard	Limitation
Front brake (one with two)	disc thickness	3.5mm	3mm
	Brake handle stroke	5~10mm	~
	Braking force	400N*m	~
Rear brake	disc thickness	3.5mm	~
	Brake handle stroke	10~20mm	~
	Braking force	500 N*m	~

● **Ignition device**

ZHEJIANG KAYO MOTOR CO., LTD.

Item		Standard
Ignition method		CDI electric ignition
Sparking plug	Type	Resistor type spark plug
	Standard	ATR7C/ (torch)
	Gap	0.6~0.7mm
	Spark character	>8mm, one bar
Spark advance angle		
Ignition coil resistance	Primary	0.43~0.57Ω
	Secondary	10.1~11KΩ
Peak voltage	Primary ignition coil	>150V
	Pulse	2V

● Light / Instrument / Switch

Item		Standard
Relay insert fuse		15A
Light	Headlight left and right	12V*3W*2
	Taillight/brake light	LED
	Gear indicator	LED

● Valve mechanism + cylinder cover (see engine section)

● Cylinder + piston + piston ring + crank connecting link (see engine section)

1.5 Fastener Torque Specifications

Note: When installing threads, please manually attach 2~3 turns of thread first.

Torque Specifications chart

No.	Item	install position	Bolt specification	Class	Moment N*m
1	Engine	Lower mounting bolt	M8	10.9	37~50
2		Upper mounting bolt	M8	10.9	37~50
3		Bottom mounting bolt	M8	8.8	18~25
4	Suspension	Brake bolts	M10*1.25	8.8	35~45
5		Axle of upper rocker arm	M10*1.25	8.8	35~45
6		Rear rocker arm bolt	M10*1.25	10.9	58~71
7		Fork axle	M12*1.25	8.8	50~60
8	Brake	Rear disc	M8	8.8	18~25 (with blue thread sealants)
9		Front disc	M6	10.9	15~20
10		Disc pump	M8	10.9	29~35
11		Front brake tee	M8	8.8	18~25
12	Rear axle	Rear axle	M12*1.25	8.8	55~65
13		Nut	M27*1.5		80~90

ZHEJIANG KAYO MOTOR CO., LTD.

14		Chain bolt	M6	8.8	8~12
15	Turning	Clamp locking bolt (hexagon)	M8	10.9	18~25
16		Steering column locking	M8	8.8	18~25
17		Bolt of lower raiser	M10*1.5	10.9	50~60
18	Electrical elements	Battery box	M8	8.8	15~20
19		Muffler installation	M8	8.8	15~20
20		Voltage regulator ignition coil	M6	8.8	7~11
21	Fuel tank, body parts, plastic	fuel tank	M6	8.8	7~11
22		fuel tank switch	M6	8.8	7~11
23		Pedal	M8	8.8	18~25
24		Reinforced pedal	M6	8.8	8~12
25		Plastic screw	TM6		7~11
26		Screw for headlight and plastic	ST4.2		3~5

● **Tightening moment at specified position - engine (see engine section)**

● **Engine service tool (see engine section)**

● **Engine special tool (see engine section)**

1.6 lubricating grease and sealant

No.	Position	Effect	Grease
1	Dust cap for rocker arms	lubrication	XHP222
2	Ball joint of rocker arms		
3	Steering column bottom		
4	Joints of knuckle and wheel hub		
5	Installation axle for rear fork		
6	Inner sleeves of rear fork		
7	Rear axle liner pipe		
8	Rear axle bearing and oil seal		
9	Steering column clamp		

Note: please coat inside of handlebar grip with grip glue before installing.

Engine operating materials and installation accessories (see engine section) Engine operating materials includes lubricating oil (engine oil), Grease (butter) and cooling liquid. The installation accessories contains flat coating glue, screw thread sealant etc.

1.7 Wiring diagram of cable, hosepipe and inhaul cable

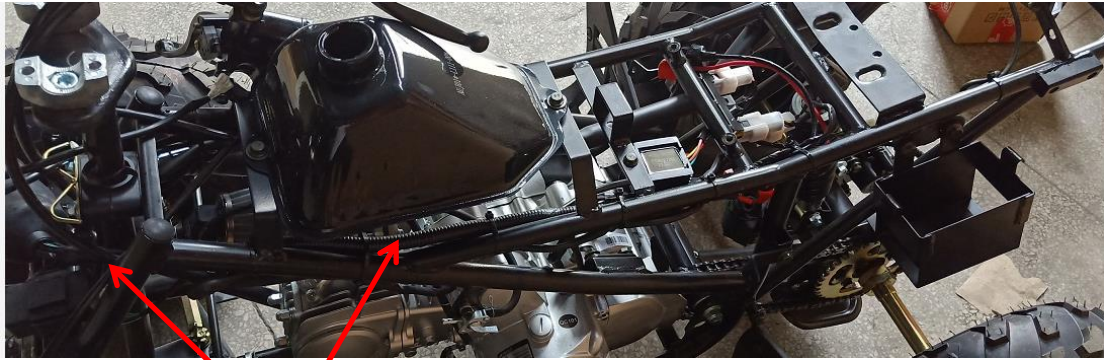

Main cable

Front Brake Line



Throttle cable

Rear Brake Line

Choke cable



- Brake switch wires
- Kill tether switch
- Neutral display
- Reverse gear display
- MultiFunctional switch

Headlight

Positive battery cable

Negative battery cable

Starter relay connector

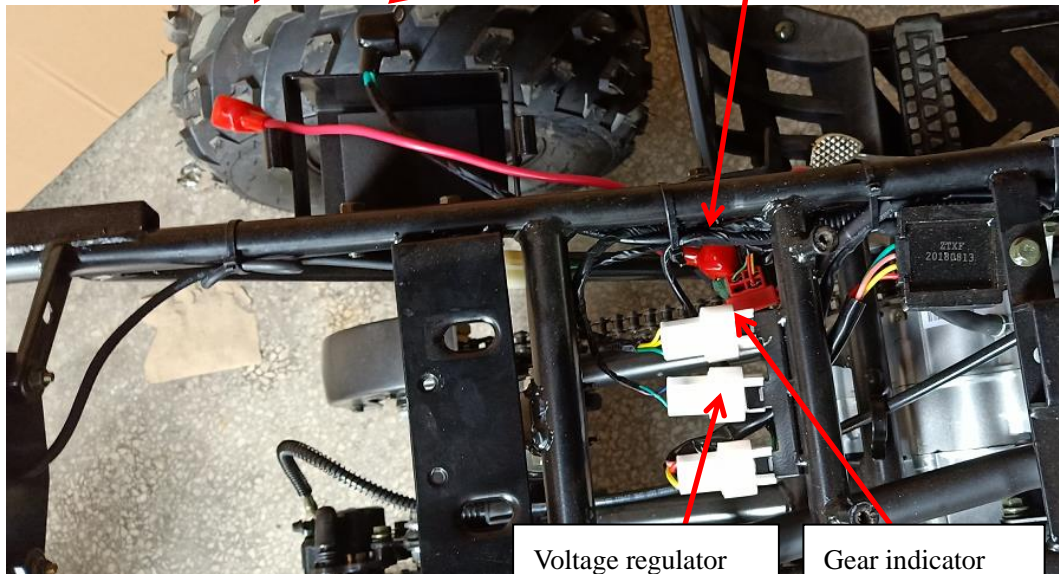

Voltage regulator

Gear indicator

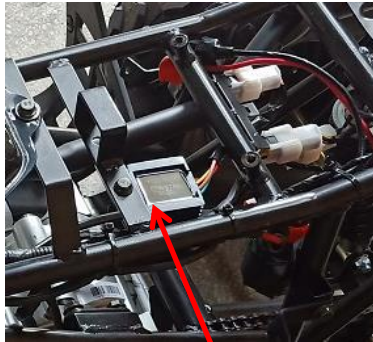

Voltage
Regulator



Taillight

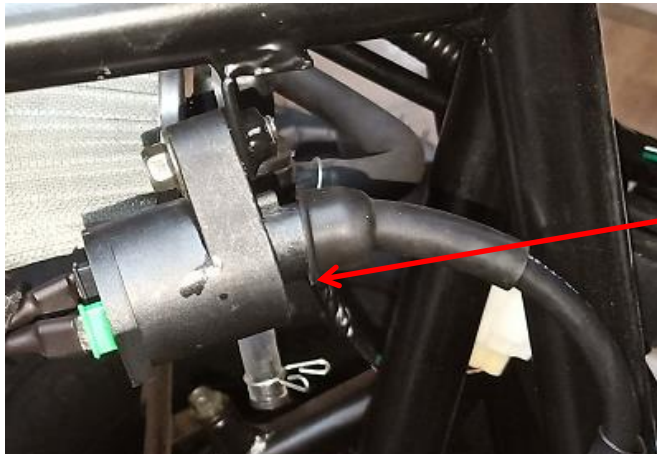

Ignition
coil



CDI

2 Plastic body

2.1 Maintenance warnings

2.2 Installation torque

2.3 Seat, front guard, clay, hood, rear body, left and right guard, plastic pedal, dismounting left and right pedal

2.1 Maintenance cautions

Operation cautions

When replacing plastics parts, please install new warning labels, stickers and riveted tags to the new plastics.

This chapter is about the dismounting the body plastics. Pipe, inhaul cable should be equipped according to wiring diagram of cable, hosepipe and inhaul cable.

2.2 Installation torque

M8 bolt: 18~25N*m

TM6 bolt: 7~11 N*m

M6* bolt: 8~12 N*m

2.3 Hood, handlebar, seat, plastic parts (clay, rear body, left and right guard), front guard, 3.2 Installation torque

2.3.1 Hood

Disassembly

1. Remove the bolts 1 and 2.
2. Push down and gently pull the hood forward to remove. (Be careful as the tabs are easy to break)

Installation

In reverse order of disassembly. Locate tabs into slots and push to lock into place then install bolts 1 and 2 (note:replace hood plastic if any of the tabs broke during disassembly)



1/2

2.3.2 Handlebar

Disassembly

1. Cut off power first. (disconnect battery)
2. Cut plastic ties first, then pluck functional switch, stop switch and brake cable plug in sequence.
3. Loose the fixed bolt from brake bar by tool and remove rear brake bar.
4. Remove front brake bar as the same as rear brake bar.
5. Pull the damper cable as picture shows, then remove it.
6. Remove the bolt from accelerator cap to remove the throttle cable.
7. Dismounting fixed bolt, then the lower raiser, remove handlebar at last.

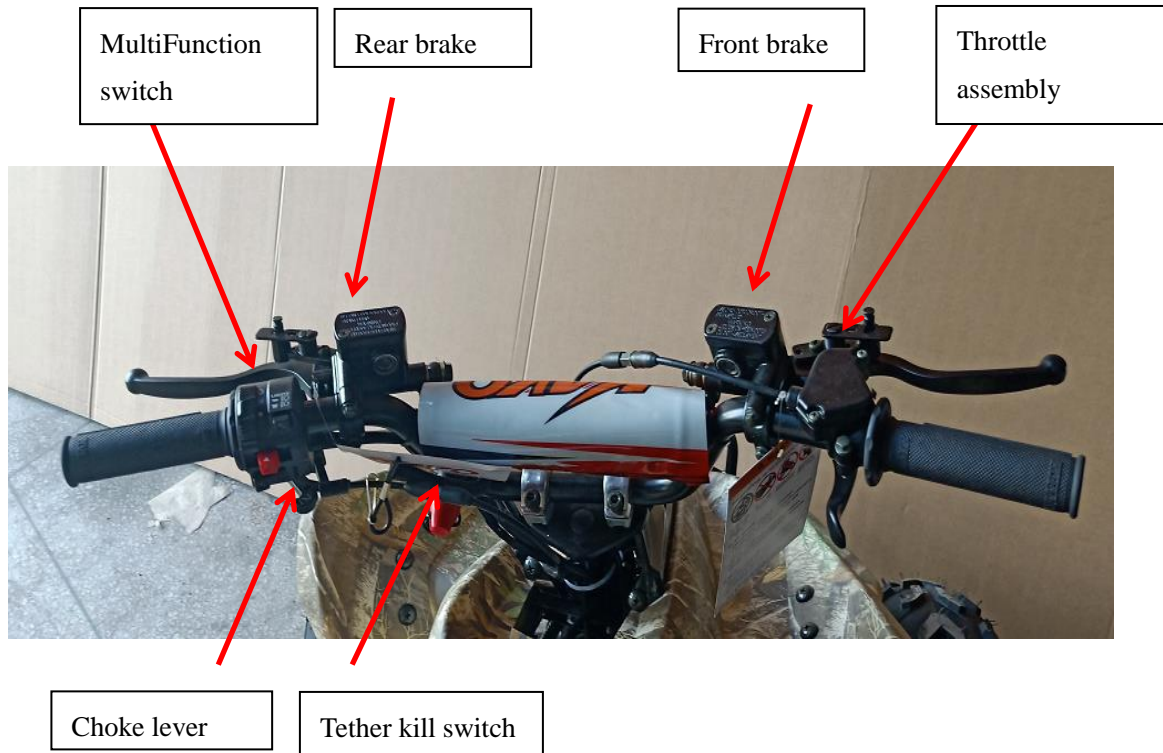

Installation

In reverse order from disassembly, then check if it installed well.

note:1. after installation, check the flame-out switch connector, function switch connector, brake connector etc., in case of misconnection or looseness.

2.Check if the dumper cable and throttle cable in right position.

3. Front and rear brake in right position, the wiring way refers to the vehicle wiring diagram.

2.3.3 Seat

Disassembly

1. Press the back of the seat cushion meanwhile open the seat cushion hook
2. Lift the seat cushion tail and pull the seat cushion back



Installation

Take it back in reverse order from disassembly.

Check if the seat is installed in place and firm.

(Note: the seat cushion front hook must be installed in the frame limit, and the seat cushion limit column must be installed in the frame limit.)

2.3.4 Front Bumper

Disassembly

1. Disassemble mounting bolt in order.
2. Remove the front guard.



Bumper
Mounting bolts

Installation

Take it back in reverse order from disassembly

(note: if the mounting bolt or nut is broken, replace it to same specification in time)

2.3.5 Plastic Body

Disassembly

1. Disconnect all necessary electrical connectors.
2. Disassemble plastic parts fixing bolts 1/2, 3/4, 5/6, 7/8, 9/10 in order. note
(2/4/6/8/10 on the other side)
3. Twist the oil cap, remove the plastic parts.

(note: remove the handlebar first before dismount plastic parts.)



1

2

3

5

Oil tank cap

4



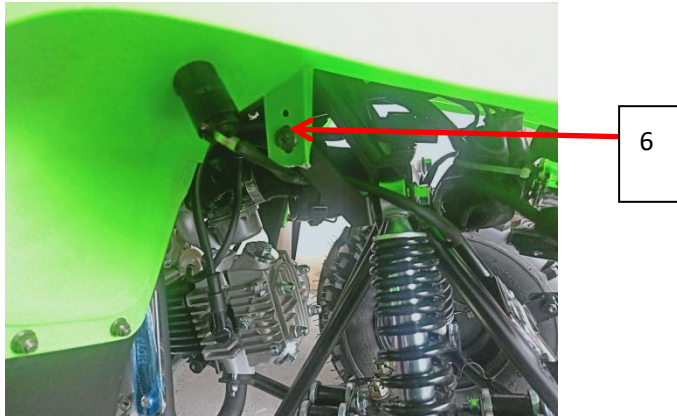

Installation

Install the plastic body in reverse order from disassembly.

(note: if the mounting bolt or nut is broken, replace it to same specification in time. After installation, check headlight connector, electric connector, reverse indicator connector etc., in case of looseness or misconnect.)

2.3.6 Left and right plastic pedal

Disassembly of right plastic part pedal

- 1、 Remove the foot mounting bolt 1 and 2
- 2、 Take the right plastic pedal

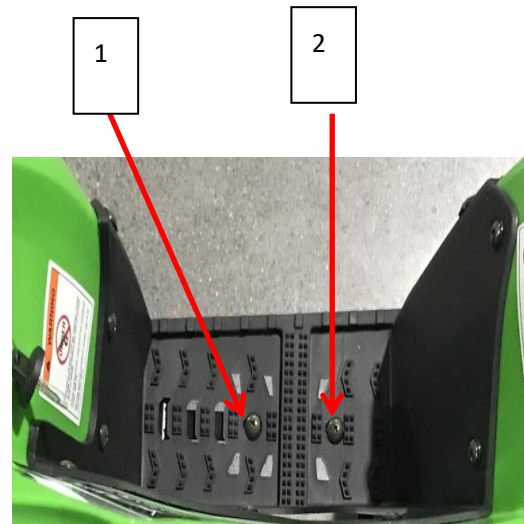

Installation

Take it back in reverse order from disassembly

(note: if the mounting bolt or nut is broken, replace it to same specification in time.)

The removal of the left pedal is the same as the right one.

3、 Regular maintenance and adjustment

3.1 Maintenance information

3.2 Maintenance period

3.3 Inspection ways

3.4 Steering column and brake system

3.5 Wheel

3.6 Suspension system

3.7 Gear box and fuel system

3.8 Throttle check

3.9 Light device

3.10 Shock absorber selection

3.1 Maintenance information

Warnings

Note:

- Do not run the engine in unventilated places, because the exhaust contains carbon monoxide (CO) and other toxic components.
- To prevent burns, don't touch the engine or exhaust until it has cooled down., please wear long sleeves work clothes and gloves.
- Gasoline is flammable and explosive. Pay attention to sparks as well as open flames. Vaporized gasoline may explode if exposed to open flame or sparks, please refuel in well-ventilated areas.
- Being careful of drive system and rotating parts, keep fingers, loose clothing and hair away from these parts

Note:

Keep the vehicle in a flat and stable place.

3.2 Maintenance period

Engine maintenance is a regular periodic work due at certain time intervals for engine maintenance, keeping up on standard maintenance will increase the lifespan and reliability of the components, the following is the AY70 engine maintenance period table.

Note: the contents in the table is based on normal conditions, if bike is ridden in dusty muddy or wet areas maintenance should be performed more often and as needed.

ZHEJIANG KAYO MOTOR CO., LTD.

A: adjustment	10 hours or 300km				
C: clean	20 hours or 750km				
I: inspection	per 50 hours or 1500km				
L: lubrication	per 100 hours or 3000km or one 年				
	per 200hours or 6000km				Remark
2 years					
Engine					
Lubricating oil and air filter		R		R	
Damper adjustment		I, A		I, A	
Engine leakproofness	I			I	
Engine suspension	I			I	
Air filter		C	R		
Sparking plug		I		I	R
Fuel system					
carburetor	I			I, L	
Driving wheel, driven wheel				I, C	
clutch				I	

Item		Period			Criterion
Parts	Item	Daily	Half year	One year	
Steering device	Steering wheel	Operating flexibility	○		
	Steering system	Damage	○		
		Installation status of steering	○		
		Ball pin shaking	○		
Braking device	Brake pedal	Pedal travel	○	○	
		Braking effect	○	○	
	Connecting rod	Slackness, looseness and	○		○
		Brake fluid	○	○	
					Above the brake fluid lower limit

ZHEJIANG KAYO MOTOR CO., LTD.

	Hydraulic brake and brake disc	Tear and damage of brake disc	○	○	○	Replace the disc in time, when front or rear brake working disc's thickness is less than 3mm.
	Brake pad	Tear and damage of brake pad	○	○	○	The minimum brake pad (friction plate) thickness $\geq 1.5\text{mm}$; less than 1.5mm, replace it.
Driving device	Wheel	Tire pressure	○	○	○	Front wheel : 45kPa (0.45kgf/ cm ²) (4.0PSI) rear wheel: 45kPa (0.45kgf/cm ²) (4.0PSI)
		Crack and damage of wheel	○	○	○	
		Tire groove depth and abnormal wear	○	○	○	If there's no tear indicator on the wheel, the residual groove depth should greater than 3mm
		Loose of wheel nut and axle	○	○	○	
		Front wheel bearing vibration	○	○	○	
		Rear wheel bearing vibration	○	○	○	
Buffer device	Suspension	Shaking of connection part	○	○	○	
	Damper	Leakage and damage	○	○	○	
		Function			○	
Transmission	Chain	Transmission and lubrication, tightness	○	○	○	Chain flapping > 20mm
	Flywheel, chain wheel	Transmission and lubrication, tightness of fixing bolt	○	○	○	If chain wheel and chain wear severity, replace it.
Electrical device	Ignition device	State of spark plug		○		
		Ignition period		○		
	Battery	Terminal connection status			○	
	Electric circuit	Looseness and damage of			○	
Fuel device		Fuel leak		○		
		Throttle condition			○	Throttle knob clearance:
Lighting device and steering indicator		function	○	○		
Exhaust pipe and muffler		Whether the installation is loose or damaged			○	
		Function of muffler			○	

ZHEJIANG KAYO MOTOR CO., LTD.

Frame	Looseness and damage			○	
Other	state of grease in frame each part			○	
Exception can be indentified in operation.	Make sure relevant parts are normal.	○			

3.4 Steering column and brake system

Keep vehicle in steady place and hold handlebar firmly as it shown in the picture to check if it's shaking.



If there is a shaking, check it's caused by steering column or other parts then repair.

If it's caused by steering column, fastening the lock nut on steering column, or you can also disassemble the steering column.

Keep vehicle in steady place and turn the handlebar slowly to check if the movement

is smooth.



If it is hard to turn, check cable, hose and wire routing, if there is no problem, check steering rods and connecting points for damage.

Note: the steering handlebar must be smooth, or it may cause accidents due to out of control. Clearance for front and rear handlebars: Check the effect and movement before operation. The clearance is 5-10mm.

Front brake pump assembly

Check the fluid level at the sight glass on the master cylinder. If brake is below the lower limit, stop using the vehicle immediately and inspect for leaks at master cylinder, hoses, fittings and connections. If fluid is low remove top of master cylinder and add DOT4 brake liquid to limit position



Note:

- When adding brake fluid, do not mix with dust and water.
- In order to prevent chemical changes, please choose the specified brand of brake fluid.
- As brake fluid will damage the plastic and rubber surfaces, please do not splash it on the parts.

Front brake disc and brake pads <wear of brake block>

The brake pads, caliper and disc are normal wear and tear items

Check or replace the brake disc

- Check the surface of brake disc, if it is worn, damaged, bent, or grooved replace.
- If the disc thickness is less than 3.0mm, replace it.

Check or replace brake pads <wear of brake block>

- Check the minimum thickness of block, If it's less than 1.5mm, replace it.
- Check for damage, cracks, and uneven wear. Replace pad set if out of specification

Note: Replace pads in sets.

3.5 Wheel

With the atv on a jack or atv lift. Lift the front wheels off the ground. Push and pull the wheel in and out as shown in the diagram.

If there is movement, check torques on hub, steering shafts, spindles.

If there is still movement, check the bearings, ball joints, a-arm bushings. Replace if worn or damaged.

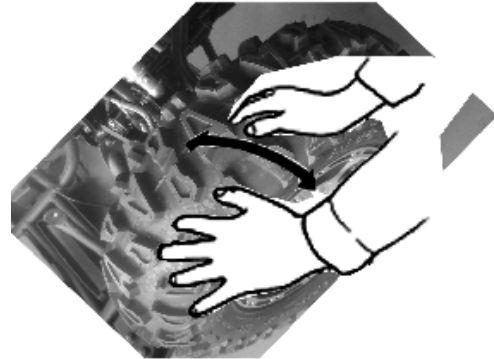

Front wheel size

On a level surface with handle bars straight check the front wheel toe-in. The front wheel relative to the forward direction of the vehicle is: A in front and B behind the wheel

Toe-in specification: $B-A=4 \sim 10\text{mm}$

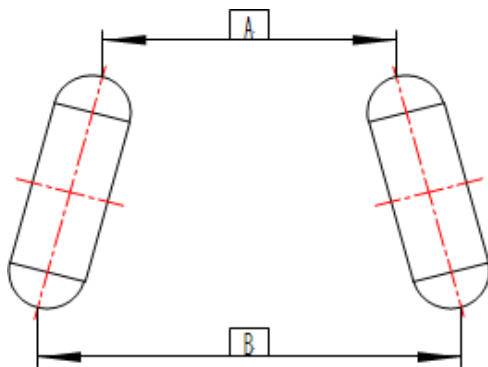

If not in this range, adjust steering rod, adjust the wheel toe-in to 4~10mm, and lock into place.

Note: after the adjustment of front toe-in size, drive the vehicle slowly until it can control the direction.

Tyre pressure

ZHEJIANG KAYO MOTOR CO., LTD.

Check the tyre pressure with a tyre pressure gauge. (pressure range: 4~6PSI)

Note: Check the tyre pressures while the tyre is cool . If tyre pressure is out of specification please adjust to within range specified. Riding with tyres out of specified range will affect vehicle handling and may cause premature wear and or damage to tyre tread



Tire tread

Check Tire tread, if tread is less than 3mm, replace it.

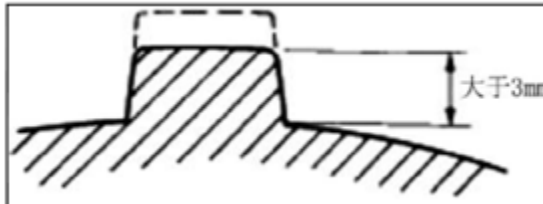

The inspection of rear wheel is the same as front wheel.

3.6 Suspension system

Keep vehicle in a horizontal position and compress up and down for several times according to the pictures. If there is shaking or abnormal sound, check whether there is oil leakage in the shock absorber, and whether there is damage or loosening in the fastening parts.



3.8 Throttle check

Check the free stroke of the throttle button. Press the accelerator several times as shown in the diagram, and check the freeplay of the thumb throttle. Under normal circumstances, there is no sticky phenomenon of the accelerator naturally.



Freeplay : 3~5mm

Adjust throttle free play if out of specification.



- | | | | |
|---|---|---|---|
| 1 | 3 | 4 | 2 |
|---|---|---|---|

ZHEJIANG KAYO MOTOR CO., LTD.

Remove sleeve for 1/2, adjust regulator 3, then turn the throttle to normal free stroke. Tighten the nut 4, install sleeve back.

If the above method is useless, replace a new throttle cable.

Speed limiting device adjustment(EPA state is not suitable)

Speed limit device is used for restrict throttle opening.

Inspect the thread length limit of speed limit screw. Thread length $a=25\text{mm}$

Adjustment: Loosen the lock nut, then adjust it with a phillips screwdriver.

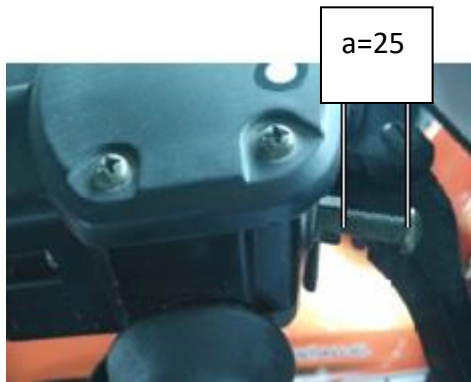

Note: For beginners, the speed limiter should be in a tight position and until the technology has reached a certain level it can be changed.

Besides, the thread length limit is 25mm. This speed limiter is fixed in EPA state.

Selection of front and rear shock absorbers

Front shock is preload adjustable.

Rear shock can be adjusted from 1 to 5.

The factory default state is position 3.

Adjustment:

1. Use shock absorber adjusting wrench (spanner).

2. Turn left the absorber get soft and right it will get hard.

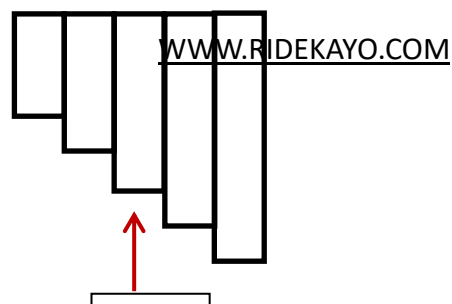



Absorber adjusting wrench

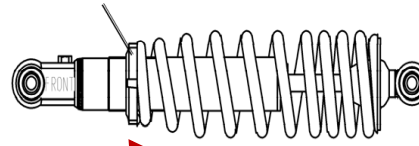

adjust the softness and
hardness of absorber

4 Engine systems

4.1 Maintenance information

4.3 Air intake system

4.2 Fuel system

4.4 Exhaust system

4.5 Disassembly and installation of engine

4.1 Maintenance information

Precautions

- Before performing maintenance, please make sure that the engine is not running.

battery is disconnected and that the heated parts have cooled, to avoid injury.

- Do not damage the frame, engine body, bolts and cables during maintenance.
- In order to protect the engine frame, please wrap the engine before operating.
- When the engine is removed, the corresponding containers should be prepared to receive coolant, oil and fuel oil for environmental protection, and the coolant and oil should be supplemented as required during installation.
- The engine does not need to be removed for the following operations.

— oil pump

— carburetor, air filter

— cylinder head cover, start motor, cylinder head, cylinder block, camshaft

— left cover, AC magneto

— piston, piston ring, piston pin

- Remove the engine in following operations.

— Crankshaft, main and counter shaft

Tightening torque

See 1.5

4.2 Fuel system

Gasoline is flammable and explosive. Pay attention to sparks and open flame. Vaporized gasoline may explode if exposed to open flame or sparks , please choose well-ventilated areas away form these hazards when refueling or working on the fuel system and its related components.

Fuel tank removal

Remove the plastic body parts, remove fuel lines from tank and fuel valve, then remove tank mounting bolts and tank.

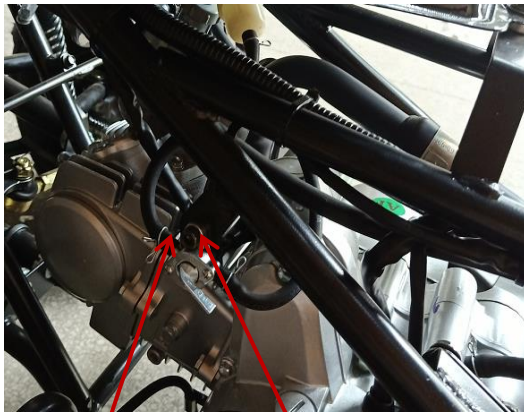

Fuel line
1

Petcock mounting bolt 2



Tank mounting
bolt

4.3 Air intake system

Disassembly

Loosen the air filter clamp and exhaust pipe to remove air filter.

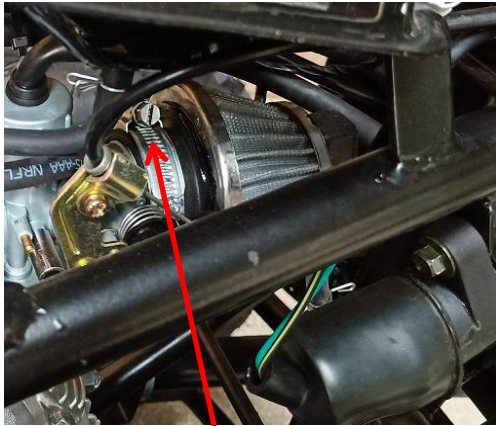

Air filter
clamp

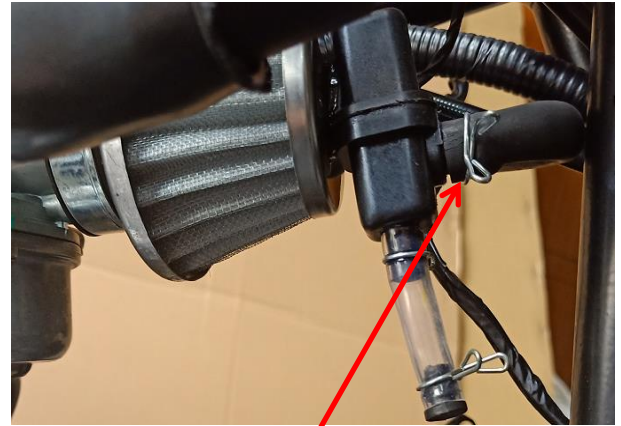

Exhaust
pipe

Installation

Installation shall be in the reverse order of removal. Make hose clamp is in the groove and any vacuum lines are hooked up correctly.

4.4 Exhaust system

Disassembly

Disassemble the clamp between muffler and exhaust head pipe, then remove the muffler mounting bolt to remove muffler.



Muffler
mounting
bolt

Remove the self locking nut 3 between exhaust mouth and exhaust pipe, then remove exhaust pipe.

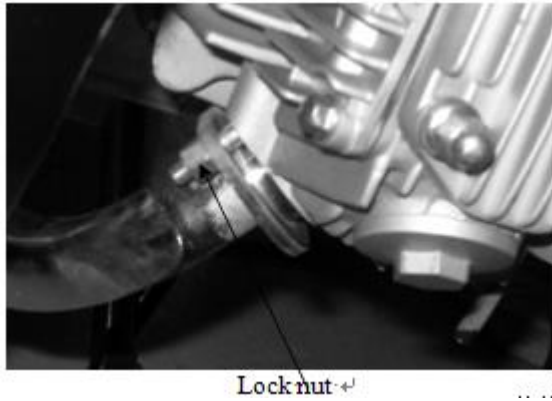

Installation shall be in the reverse order of removal. Note if exhaust pipe seal pad 4, graphite sleeve 5 for muffler mounting and locking nut damaged, replace at once.

4.5 Disassembly and installation of engine

Disassembly (Note: Remove pedal first)

1. Remove the engine side cover, then remove chain.
2. Remove the ground lead, gear indicator cable, magneto cable, start motor cable, exhaust pipe, ignition coil cap and gearshift.

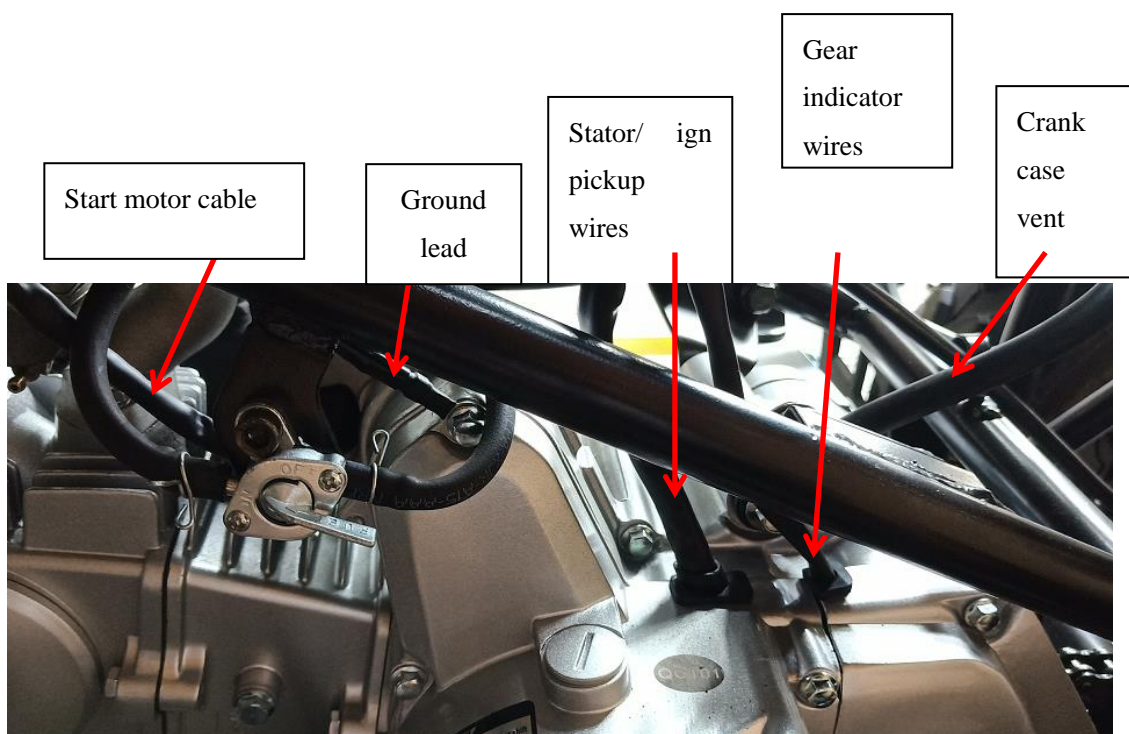

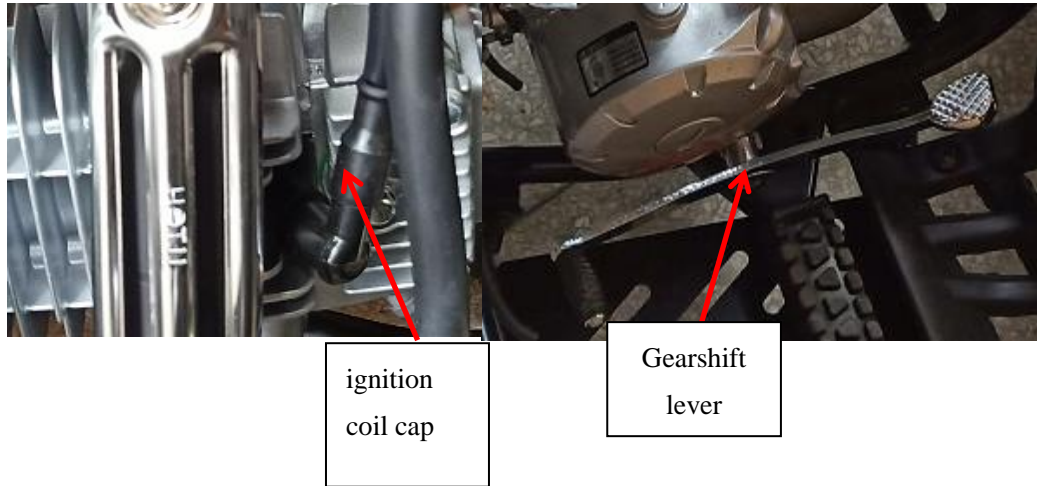

3. Remove the power bolts, lug, and bolt of engine bottom.

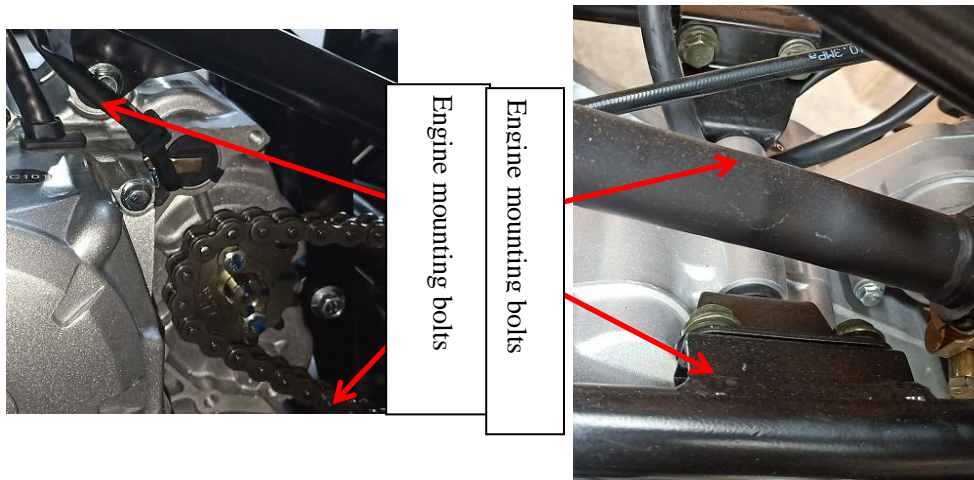

4. Remove the engine from the right side of vehicle.

Installation

Installation shall be in the reverse order of removal.

5 Engine

5.1 Maintenance information

Conversion table refers

Item	Unit conversion
Pressure	$1\text{kgf/cm}^2=98.0665\text{kPa}$ $1\text{kPa}=1000\text{Pa}$
Torque	$1\text{mmHg}=133.322\text{Pa}=0.133322\text{kPa}$ $1\text{kgf}\cdot\text{m}=9.80665\text{N}\cdot\text{m}$
Volume	$1\text{mL}=1\text{cm}^3=1\text{cc}$ $1\text{L}=1000\text{cm}^3$
Moment	$1\text{kgf}=9.80665\text{N}$

Danger/warning/attention

Take it seriously, it's important for maintenance.

Danger: Be on high alert for danger.

Warn: to be alert to moderate danger.

Attention: to be alert to minor danger.

This manual may doesn't contain some potential risks in engine work and maintenance; the service operator should also have basic mechanical knowledge.

General precautions

Warning:

Proper maintenance is very important to engine reliability and personnel safety.

● When there is two or more people work together, more attention should be paid for safety.

ZHEJIANG KAYO MOTOR CO., LTD.

- When starting the engine indoors, be sure to vent the exhaust outside.
- If toxic or flammable substances are used, handle that in accordance with the manufacturer's instructions strictly and make sure workplace must be well ventilated.
- Don't use gasoline as a cleaning fluid
- To avoid burns, do not touch uncooled engine oil, exhaust system parts
- If the fuel, lubrication and exhaust systems are serviced, please check the marker and leakage.
- In order to protect the environment, oil replacement parts can't be disposed.

Warning:

- **If parts need to be replaced during maintenance, please choose parts which recommended or provided by Kayo.**
- **Disassembled parts that need to be reused should be arranged in order, it's helpful to assembly.**
- **Choose special tools as specified in the maintenance manual.**
- **Ensure that parts used in assembly are clean and must be lubricated where required.**
- **Use special lubricants, binders and sealants.**
- **When fastening bolts, screws and nuts, first tighten the large size, and tighten from inside to outside according to the specified torque.**
- **Use a torque wrench to tighten the torque required bolts, if there is grease and oil on the thread, it must be erased.**
- **Clean the disassembled parts before inspection and measurement.**
- **After assembly, check the fastening and running status of**

5.2 Engine oil and fuel

Fuel: Use octane 93# or higher unleaded gasoline

Engine oil: Use sae15w-40 oil for 4 stroke motorcycle, quality grade

Warning: Engine oil shall not be mixed with engine oil of other brands

according to the classification of the API SG level or by the superior, if no SAE15W - 40 oil, according to the engine using the environment

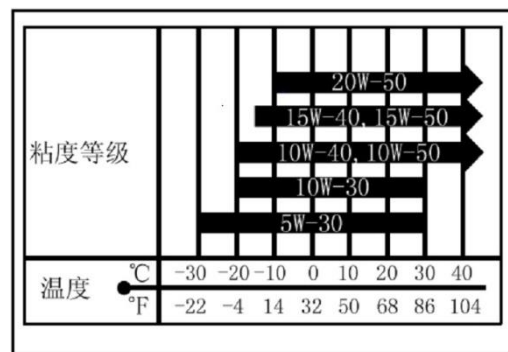

5.3 Engine brake-in

Engine has a lot of relative motion components, such as piston, piston ring, cylinder block, mutually meshing transmission gear wheel, etc. therefore, a standard break-in is very important at the beginning of the its use, it can make the moving parts to adapt to each other, correction work, form good heavy load to bear a smooth friction surface. Through this process the engine will has excellent performance and reliability. Recommended break-in time: 20 hours, details as follows:

0~10 hours

Avoid continuous operation, constantly changing speed and not operating in a fixed throttle position when the throttle is more than 50%; Cool the engine for 5 to 10 minutes after each hour of operation. Avoid rapid acceleration, throttle change should be slow.

10~20 hours

Avoid operating longer than 3/4 throttle. Use freely but do not use full throttle.

5. 4 Engine number



Engine Number

Engine head displacement label



displacement

5. 4 Maintenance

Subsidiary

maintain times Items	Odometer reading			
	1000km	4000km	8000km	12000km
Fuel system	Clean	Clean	Clean	Clean
Oil filter	Clean	Clean	Clean	Clean
Control	Adjust	Adjust clean	Adjust clean	Adjust clean
Carburetor	Clean	Clean	Clean	Clean
Air cleaner	Clean	Clean	Clean	Clean
Spark plug gap	Adjust	Adjust clean	Adjust clean	Adjust clean
Valve clearance	Adjust	Adjust	Adjust	Adjust
Engine lubrication	Replace	Replace once per 2000km		
Filter media	Clean	Clean	Clean	Clean
Timing chain	Check	Adjust	Adjust	Adjust
Carburetor idle speed	Adjust	Adjust	Adjust	Adjust
Drive chain	Adjust and lubricate per 5000km			
Battery	Charge	Charge	Charge	Charge
Brake disc	Check	Adjust	Adjust	Replace 更換
Brake system	Adjust	Adjust	Clean	Clean
Brake light switch	Adjust	Adjust	Adjust	Adjust
Illuminating system	Check	y	Adjust	Adjust
Clutch	Adjust	Adjust	Adjust	Adjust
Shock absorber	Adjust	Adjust	Clean	Clean
Nuts/bolts	Tighten	Tighten	Tighten	Tighten
Front and rear wheel	Check	Check	Check	Replace
Turn handlebar bearing	Check	Adjust	Adjust	Replace

5.4 Maintenance of Engine Body

5.4.1 Disassemble, assemble and maintain cylinder head

Right view of the 125 engine is shown in the figure.

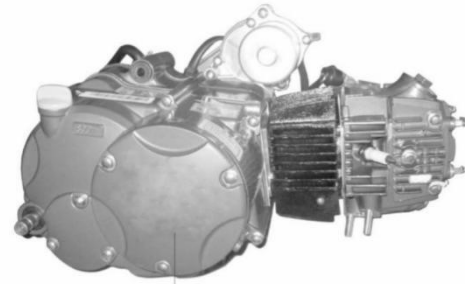

right view of 125

Left view of the 125 engine is shown in the figure.



left view of 125

Remove the locknut of cylinder head from its holding place

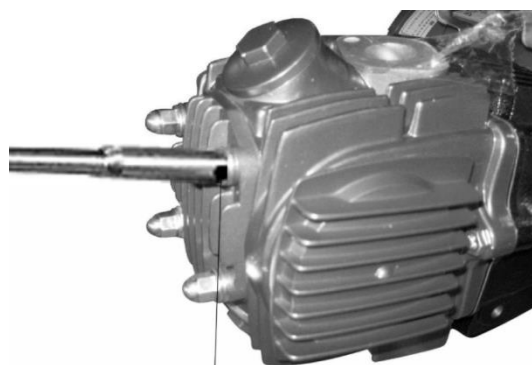

Locknut

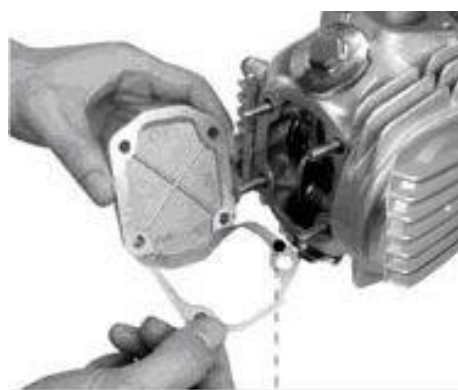

paper pad

Remove cylinder head. Check the state of paper pad. Replace if necessary.

Dismantle the fixing bolt of left cover.

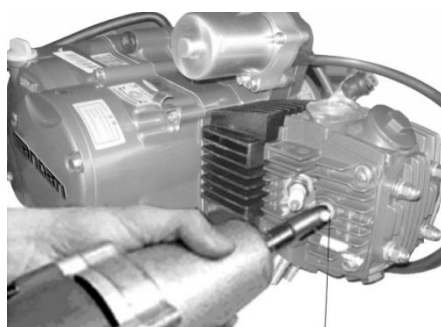

fixing bolt

Remove left cover and inspect the paper pad for damage. Replace if necessary.

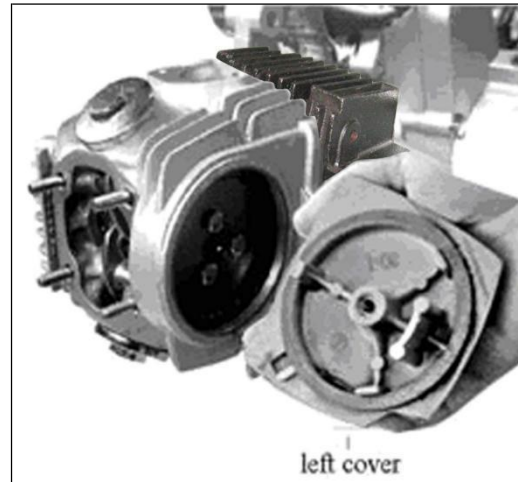

Dismantle the fixing bolt of right cover.

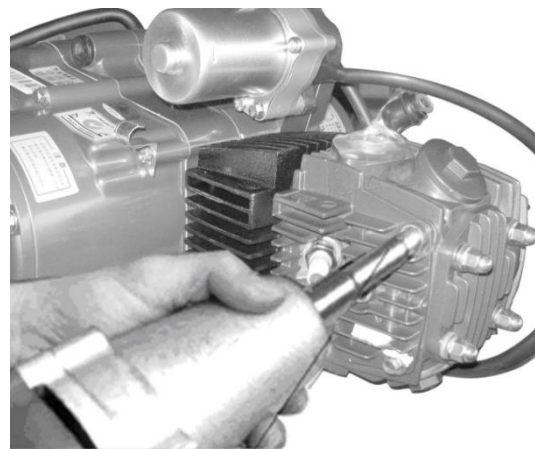

Remove the right cover of cylinder head.
Inspect the gasket for damage and replace if necessary.



paper pad

Remove inlet/exhaust valve cap .Check the state of seal ring of valve cap and replace if worn or if reuse is questionable.

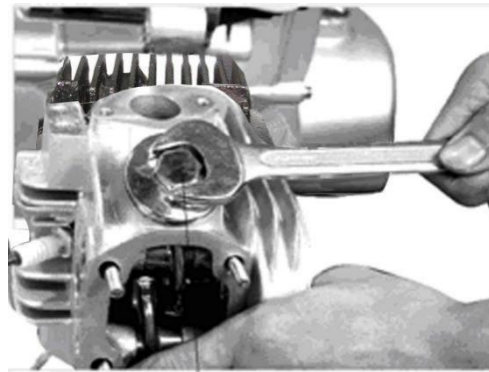

valve cap

Remove the fixing bolt of timing driven sprocket.



fixing bolt

Remove the connecting bolt of
cylinder head.

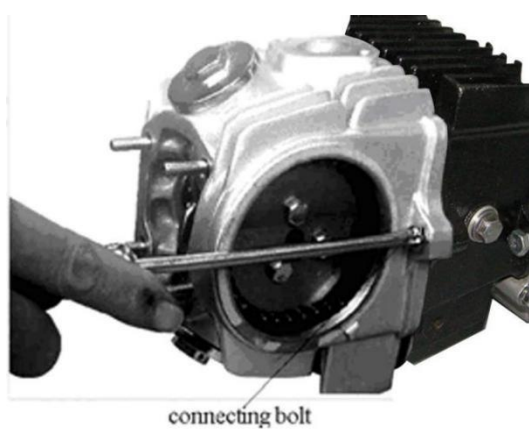

Remove cylinder head assembly.

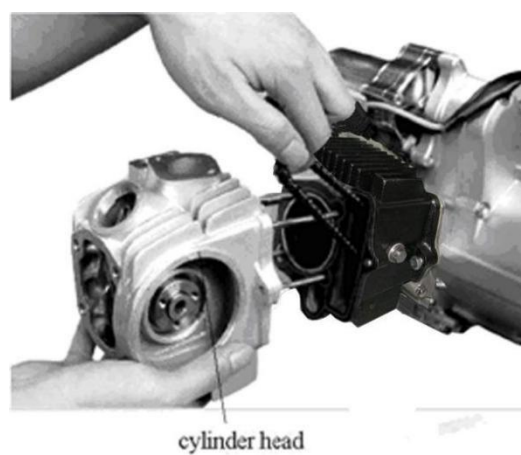

Remove timing driven sprocket. Inspect the timing driven sprocket for wear and damage. Replace if necessary.

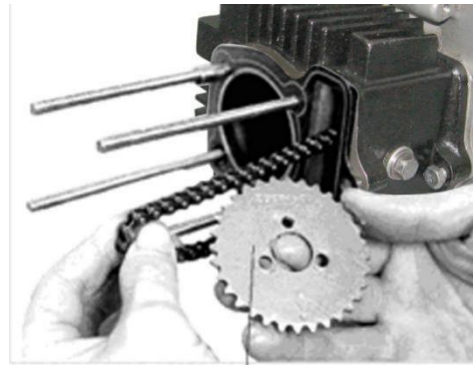

timing driven sprocket

Check whether there is excessive carbon deposit in combustion chamber. Clean and replace if necessary



combustion chamber

Remove the cylinder head. Pour gasoline into inlet/exhaust pipe to inspect the seal condition. Grind the valve and valve seat if there is gasoline leak into the combustion chamber.



oil seal

Remove inlet/exhaust valve spring and check the state. Replace if necessary.

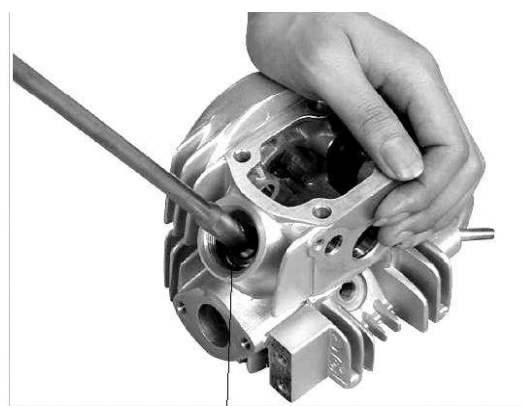

valve spring

Inspect the oil seal of inlet/exhaust valve for damage. Replace if necessary.

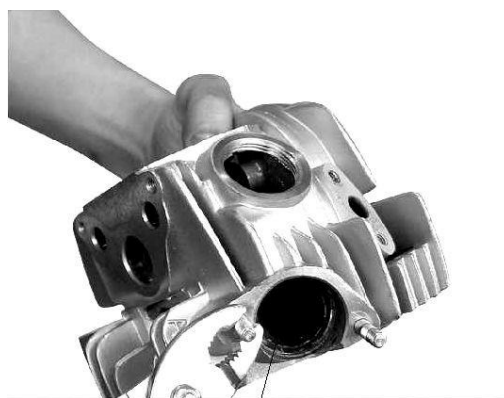

cylinder head

ZHEJIANG KAYO MOTOR CO., LTD.

Remove the spark plug to clean the carbon.

Deposit and dust .Check the spark plug gap and set it to 0.6 to 0.7 if necessary.



spark plug

For the troubleshooting of cylinder head ,please refer to the following table

Description	Damage Form	Problem	Cause	Correction
Cylinder	Too much oil dirt or sand on the cooling fins.	Poor heat radiation of the fins on cylinder head.	The engine overheats.	Remove the oil dirt or sand
	Carbon deposit in the combustion chamber	Overheating head	The engine overheats	Remove the carbon deposit
	Failure of sparking plug threaded hole	Air leakage between the sparking plug and cylinder head	The engine starts hard or fails to start	Repair the threaded hole or replace the cylinder head
	Serious deformation of cylinder head end surface	Air leakage between the cylinder head and cylinder	The engine starts hard or fails to start. Insufficient engine output ;Engine speed changes during idle run	Grind the cylinder head end surface or replace the cylinder head
	There are pits, ablation or pock marks, damages on the working surface of valve seat.	Air leakage between the valve and valve seat due to improper tightness	The engine starts hard or fails to start. Insufficient engine output; engine speed changes during idle run	Repair the valve seat
	The inner hole of valve guide is over worn	The fitting clearance between the valve and the valve is too large	Thick blue and white fume form the exhaust muffler pipe	Replace the valve guide
	The cylinder gasket is broken	Air leakage between the cylinder head and cylinder	The engine starts hard or fails to start. Insufficient engine output; Engine speed changes during idle run	Replace the cylinder head gasket
	The fixing nut is not properly tightened	Air leakage between the cylinder head and cylinder	The engine starts hard or fails to start. Insufficient engine output; Engine speed changes during idle run	Tighten the fixing nut
Spark plug	Improper clearance between electrodes	Weak or no sparking from the spark plug electrodes	Oil leakage between the cylinder and crankcase	Adjust electrode gap to 0.6~0.7mm
	The spark plug electrodes are jointed by carbon deposit	No sparking from the spark plug electrodes	The engine starts hard or fails to star	Remove the carbon deposit between the electrodes
	Excessive carbon deposit or oil dirt in the spark plug	Weak or no sparking from the spark plug electrodes	The engine starts hard or fails to start. Insufficient engine output; Engine speed changes during idle run	Remove the carbon deposit or oil dirt
	The spark plug insulator is damaged	Weak or no sparking from the spark plug electrodes	The engine starts hard or fails to start. Insufficient engine output; Engine speed changes during idle run	Replace with a new spark plug of the same type
	The spark plug is not properly tightened	Air leakage between the spark plug and cylinder head	The engine starts hard or fails to start. Engine speed changes during idle run	Tighten the spark plug

5.4.2 Disassemble, assemble and maintain cylinder block

Remove cylinder gasket and dowel pin to check for wear and damage. Replace if necessary.

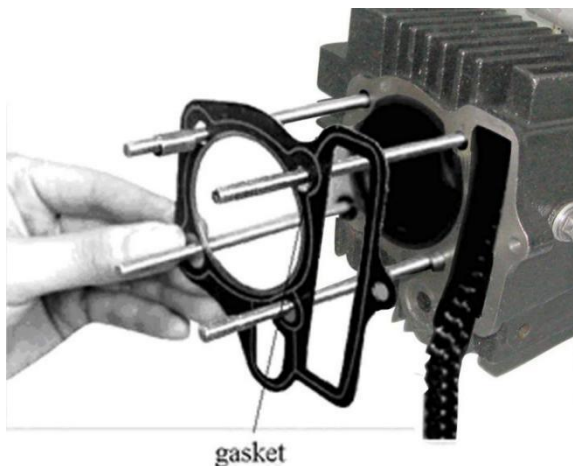

Dismantle connecting bolt of cylinder block.

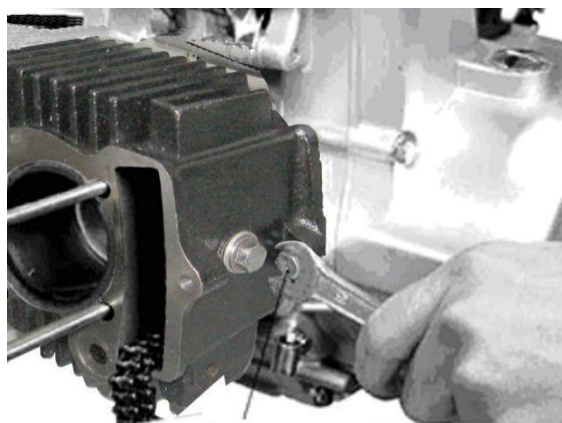

connecting bolt

Dismantle the fixing bolt of timing chain of guide wheel.

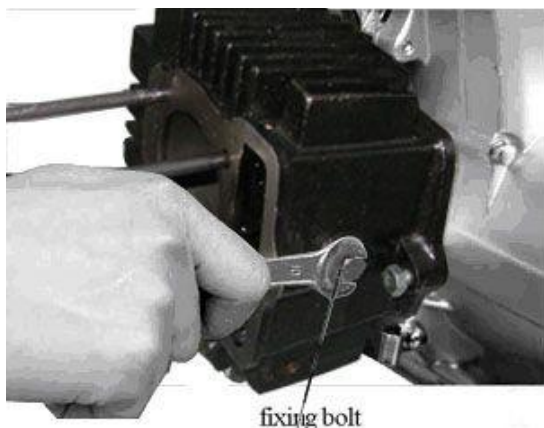

Remove the cylinder block.

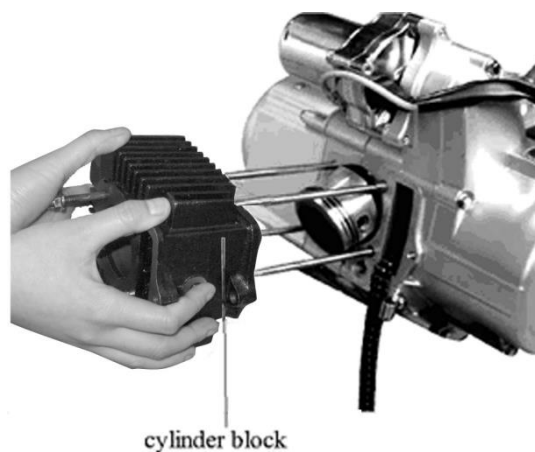

Remove the guide wheel of timing chain to inspect for wear and damage. Replace if necessary.

Remove the circlip of piston pin.

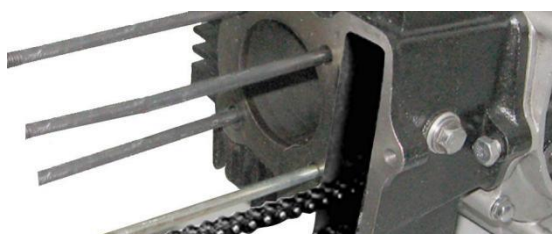

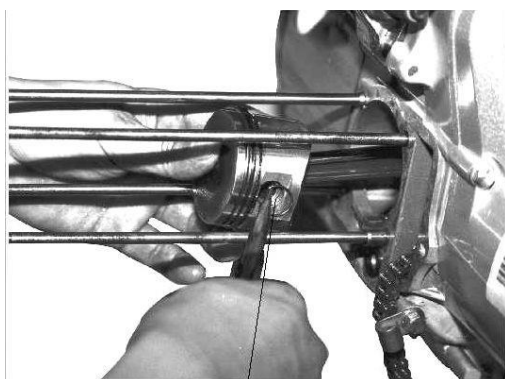

piston pin circlip

Remove the piston of piston pin to check whether it is damaged. Replace if necessary.

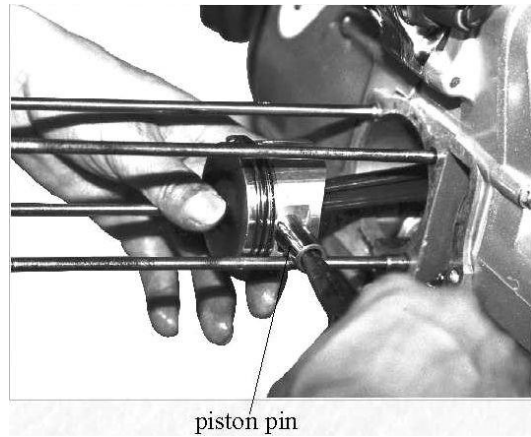

Inspect the paper pad for worn or damage .Replace if necessary.



Check whether there is residual gasket on cylinder. Clean with gasoline if necessary.

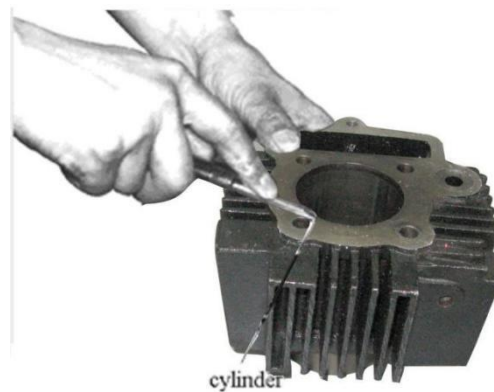

Check the state of cylinder inner wall .Replace if worn or if reuse is questionable.



inner cylinder wall

Check whether the internal diameter has exceed the limit value. Measure the diameter form upper, middle and lower position. The limit value is 52.05mm.Replace the cylinder block if it has beyond this value.



cylinder block

ZHEJIANG KAYO MOTOR CO., LTD.

Troubleshooting of the cylinder body, please refer to the following table

Maintenance of Cylinder Body

Description	Damage form	Trouble	Cause	Correction
	Excessive oil dirt or sand on the radiating fins	Poor heat radiation of the fins on cylinder body	The engine overheats	Remove the oil dirt or sand
	Cylinder end surface badly distorted	Air leakage between the cylinder and cylinder head	The engine starts hard or fails to start .Insufficient engine output; poor idle speed and high fuel consumption	Grind the cylinder end surface or replace the
	The cylinder is badly worn	The fitting clearance between the cylinder and position, position ring is too wide	The engine starts hard or fails to start .Insufficient engine output; Poor engine idle speed. Thick blue and white fume form the exhaust muffler pipe	Repair with boring machine or replace the cylinder body
	The cylinder Gasket is damage		Oil leakage between the cylinder and crankcase	Replace the cylinder gasket

5.4.3 Disassemble, assemble and maintain crankcase

Remove the cover of right crankcase half.
Check whether the oil seal of starting shaft
and seal edge of gearshift lever are worn.
Replace if necessary.



Check the state of right crankcase
cover and replace if necessary.

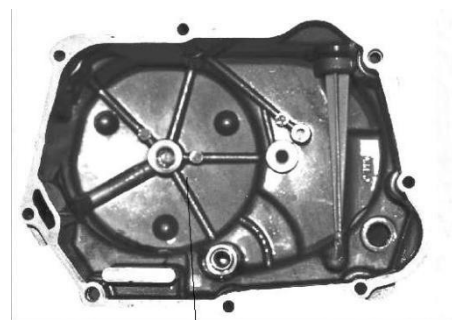

right crankcase cover

Left view of right crankcase half is shown in fig and check whether bearing of main shaft and countershaft are worn. Replace if necessary.

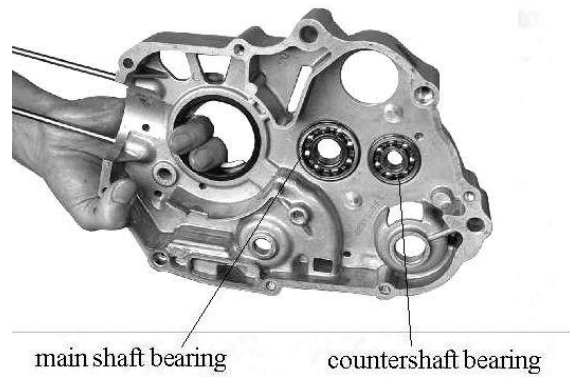

Right view of right crankcase half is shown in fig and check the state of right crankcase half. Replace if necessary.

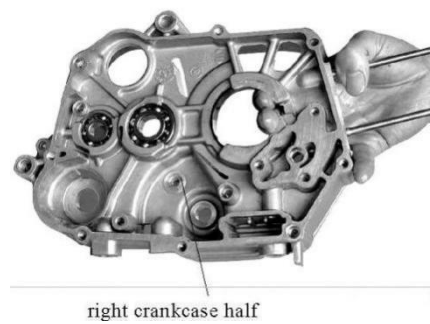

Left view of left crankcase is shown below and check whether the oil seal of countershaft and oil seal edge of gearshift lever are worn .Replace if necessary.

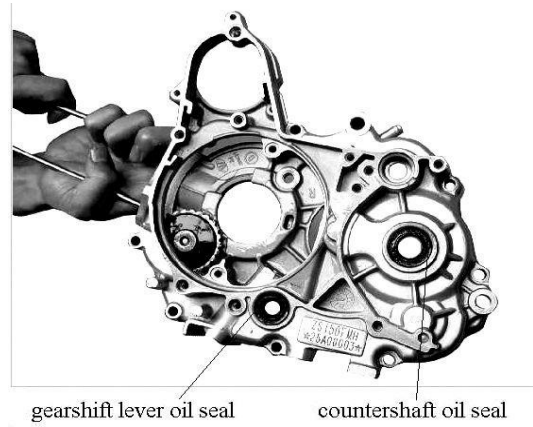

Right view of right crankcase half is shown in fig and check whether bearing of main shaft and countershaft are worn. Replace if necessary.

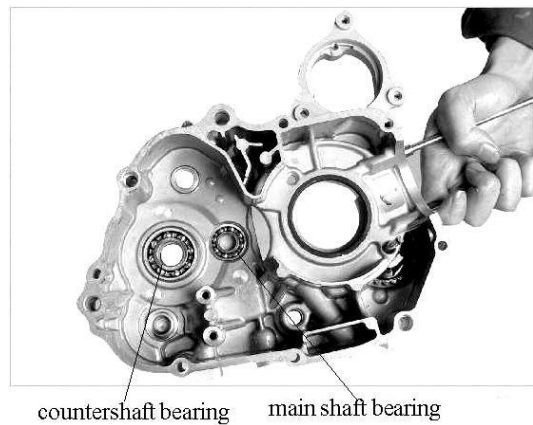

Dismantle fixing bolt of left crankcase cover.

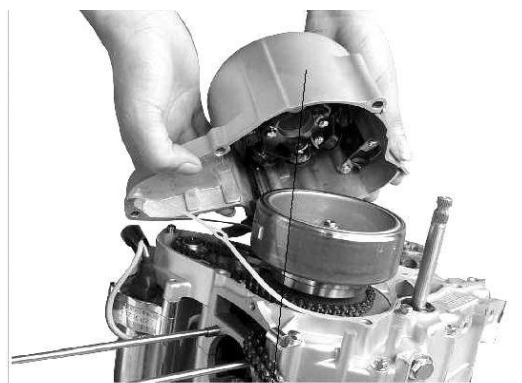

magneto stator

Remove the neutral indicator and check the state. Replace if necessary.



neutral indicator

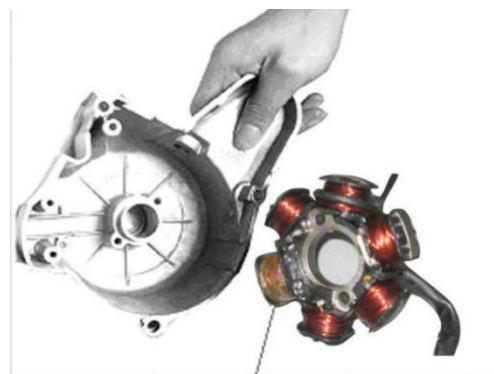

magneto stator

Dismantle the fixing bolt of magneto stator and remove the stator.

Check the condition of left crankcase



cover and replace if necessary.

Troubleshooting of crankcase, please refer to the following table.

Description	Problem	Trouble	Compuaction	Correction
	Crack in the crank case		Oil leakage from the	Repair or replace the
	Oil leakage from the joint of left and right		The crankcase gasket is worn out	Replace the gasket
	The threaded hole of oil drain plug screw is		Oil leakage from the threaded hole of plug	Repair of replace the crankcase
	The threaded holes of cylinder bolt are ineffective	Cylinder head retaining nut is impossible to screw up firmly, resulting in air leakage	The engine starts hard or fails to start. Insufficient engine output; Engine speed changes during	Repair the threaded or replace the crankcase
	The bolt of the cylinder	The same as front	The same as front	Replace the cylinder bolt
	The oil seal is damaged or the oil seal edge is	Oil leakage is ineffective	Oil leakage from the oil seal	Replace the oil seal
Right crankcase cover	The right crankcase		Oil leakage form the	Repair or replace the
	The gasket of right crankcase is broken		Oil leakage between the case cover and the	Replace the gasket
Left crankcase cover	The left crankcase cover		Oil leakage form the	Repair or replace the
	The gasket of left crankcase is broken		Oil leakage between the case cover and the	Replace the gasket

5.4.4 Maintenance of Crankshaft Connecting Rod

Disassemble, assemble and maintain crankshaft connecting rod

Remove the fixing bolt of crankcase from its holding place.

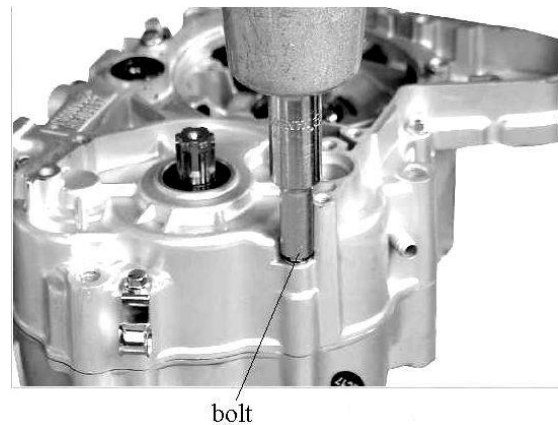

Remove left crankcase half. Take care not to forget the washer of mainshaft and countershaft when removing the left crankcase.

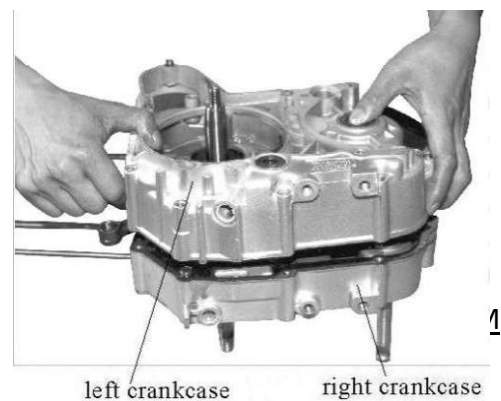

Remove the paper pad to inspect for wear and damage. Replace if necessary.

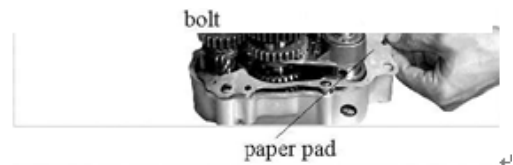

Remove the connecting rod assembly.



Inspect connecting rod bearing for wear and damage. Replace if necessary.

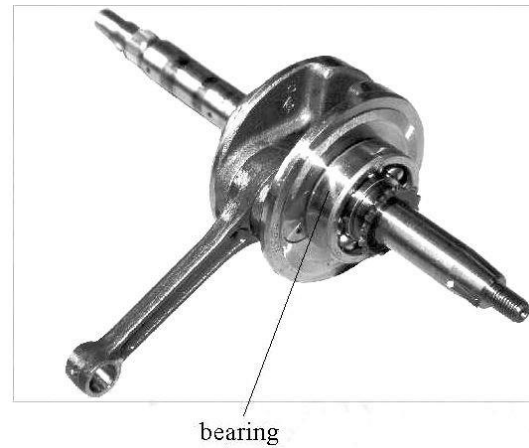

Check gap of big-end of connecting rod.
Reset the gap if necessary.



Check diameter of piston pin using a micrometer. Replace the piston pin if the value is over the maintenance limit value.

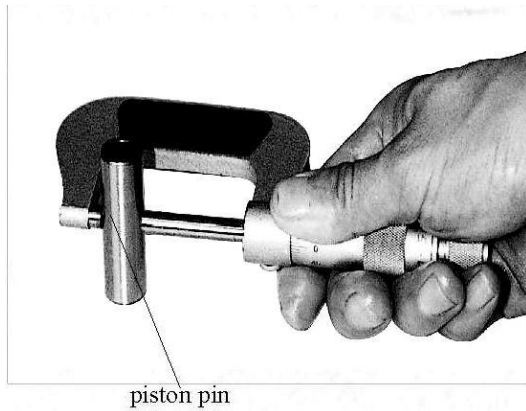

Check the axial and radial jumping of connecting rod bearing. Replace the conrod if the jumping is large.

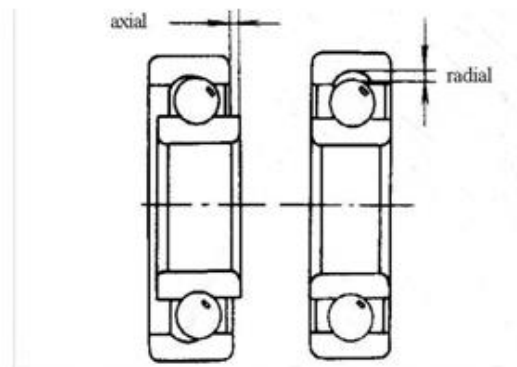

Check the side gap between piston ring and piston groove using a feeler gauge. Replace the piston if the gap is too wide.

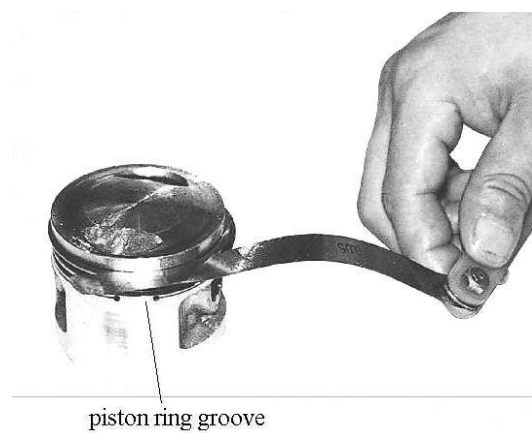

Check whether there is excessive carbon deposit on piston top and groove. Remove if necessary.

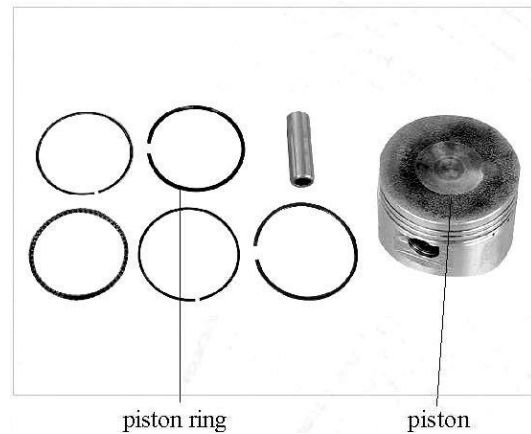

Check the state of piston and replace if worn or if reuse is questionable. Measure diameter of piston skirt. Replace it if the value is beyond the maintenance limit value.

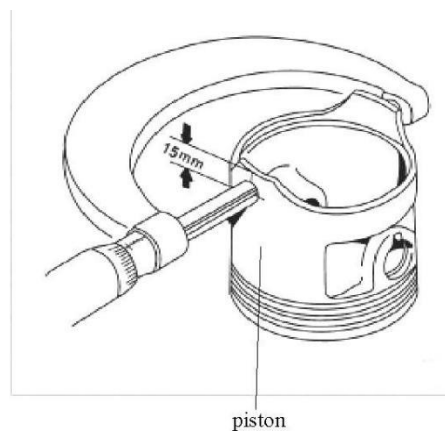

Assemble the piston ring according to the figure and check whether piston ring is damaged or the elasticity is weakened. Replace if necessary.

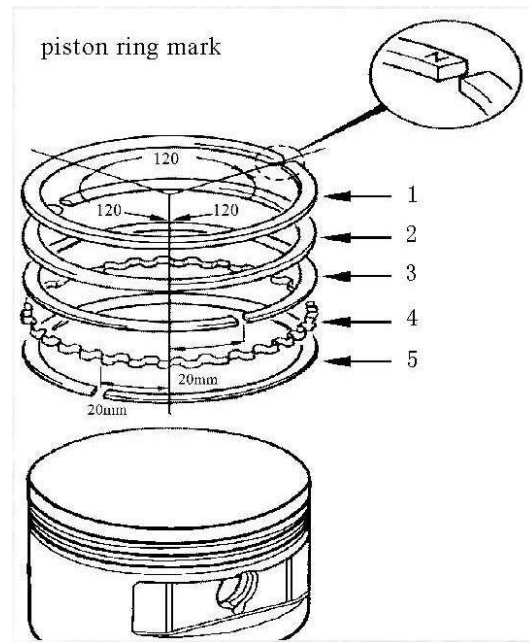

**For the troubleshooting of crankshaft connecting rod mechanism,
please refer to the following table.**

Maintenance of Crankshaft Connecting Rod Mechanism

Description	Damage from	Trouble	Cause	Correction
Piston	Carbon deposit on piston top		The engine over- heats	Remove the carbon deposit
	Carbon deposit in the ring groove	The piston ring is seized in ring groove	The engine starts hard or fails to start. Insufficient engine output;	
	Scuffing or scratches on the surface of piston skirt	Scuffing or scratches on the surface of piston skirt	Thick blue and white fume form the exhaust muffler pipe	
	The piston and ring groove are over worn	Excessive fitting clearance between the piston and the cylinder	The engine starts hard or fails to start. Insufficient engine output; Thick blue and white fume form the exhaust muffler pipe	Replace the piston
	The piston pin hole is over worn	Excessive fitting clearance between the piston ring and the hole.	Striking sound of the piston pin and of the cylinder	

ZHEJIANG KAYO MOTOR CO., LTD.

Crank pin	The crank pin is over worn	Radial and axes gap of the connecting rod big end is too large	Striking sound of the big-end bearing; Striking sound of the cylinder	Replace the crankshaft connecting rod
Bearing	The big-end needle bearing is over worn	Radial and axes gap of the connecting rod big end is too large	Striking sound of the big-end bearing; and of the cylinder	Replace the crankshaft connecting rod
	The crankshaft bearing is over worn or damaged		Abnormal sound during the crankshaft bearing transmission	Replace the crankshaft bearing
Piston ring set 活塞环总成	The piston ring is fractured	The piston ring is fractured	The engine starts hard or fails to start. Insufficient engine output; Thick blue and white fume form the exhaust muffler pipe 发动机启动很难或无法启动。 发动机输出不足; 厚厚的蓝色和白色烟雾充满消声器	Replace the piston ring set
	The piston ring is over worn	The piston ring opening gap or the side gap is too wide		
	Insufficient elasticity of piston ring	It is impossible to tight the piston ring and the cylinder properly	Thick blue and white fume form the exhaust muffler pipe	Refixing the piston ring set
	Improper fixing	The piston ring gap is not staggered		
Piston pin	The piston pin is over worn	The fitting clearance between the piston pin and the hole is too wide	Striking sound of the piston pin and of the cylinder	Replace the piston pin
Connecting rod	The connecting rod small-end hole is over worn	The fitting clearance between the piston pin and the small-end is too wide	Striking sound of the piston and of the cylinder	Replace the connecting rod
	The connecting rod is crooked or twisted	The connecting rod is crooked or twisted	Striking sound of the cylinder	Replace the connecting rod
	The big-end hole is over worn	Radial and axes gap of the connecting rod big end is too large	Striking sound of the big-end bearing and of the cylinder	Replace the connecting rod
Timing sprocket	The gear is over worn of damage		Abnormal sound during sprocket driving	Replace the timing sprocket

5.5 Maintenance of Mechanism

5.5.1 Disassemble, assemble and maintain valve mechanism

Remove rocker arm shaft

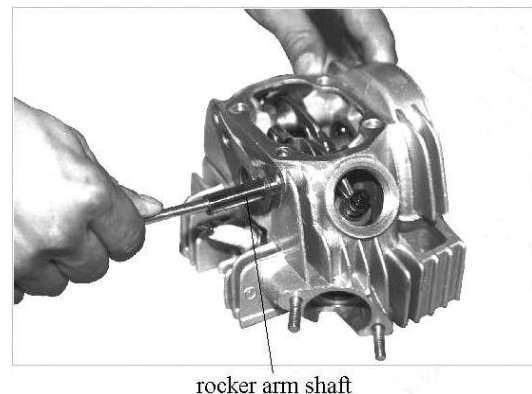

Remove the rocker arm of inlet/exhaust valve and check the state

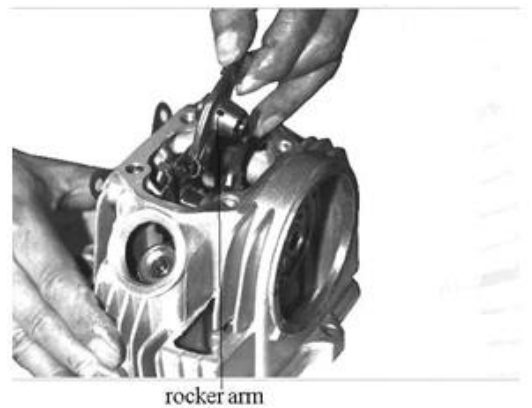

Remove the timing cam, rocker arm , rocker arm shaft to inspect for worn. Replace if necessary.

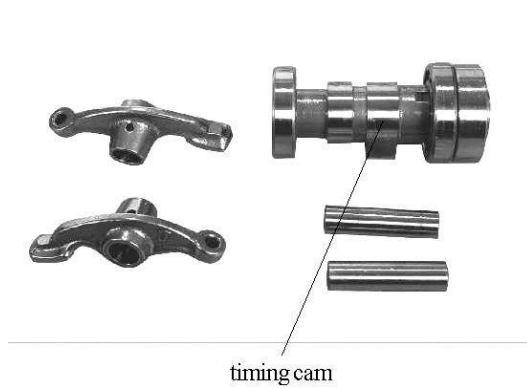

Remove the circlip of inlet and exhaust valve. Remove inlet valve stem and exhaust valve stem take care and don't miss the valve clip.

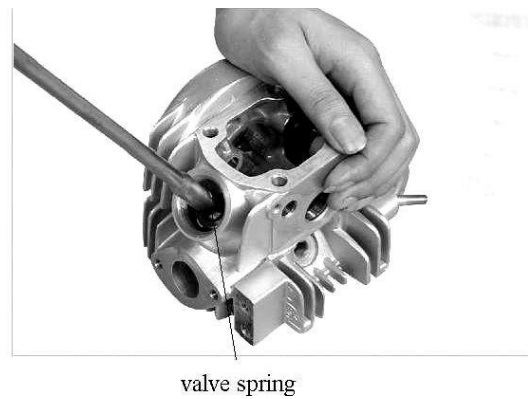

Measure length of valve spring to check whether the spring is damaged or worn. Replace if necessary.

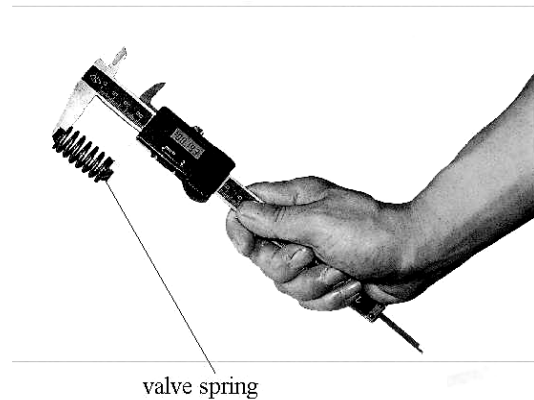

Note: when assemble the valve spring , make sure its dense end downward.

Remove the spring of inlet and exhaust valve to inspect for wear and damage.

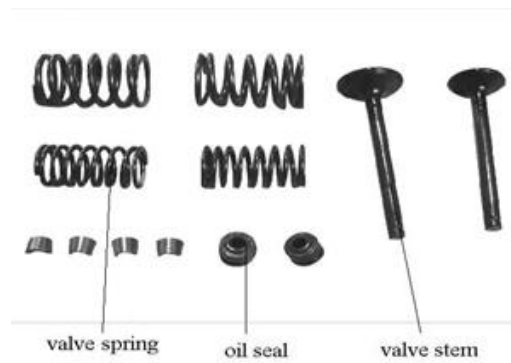

Check the external diameter of valve stem using a vernier caliper. Replace the valve stem if the valve is beyond the maintenance limit valve.



valve stem

Measure the width of valve contact surface to check whether the contact surface is rough or abnormal. Replace the valve stem if the valve is large than 1.5mm.



valve contact surface

Check whether the valve stem is distorted.

Replace if necessary.

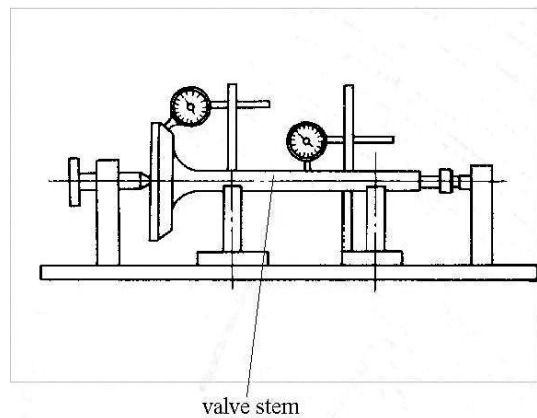

Inspect the timing camshaft bearing for wear and check the state of camshaft.

Replace if necessary.

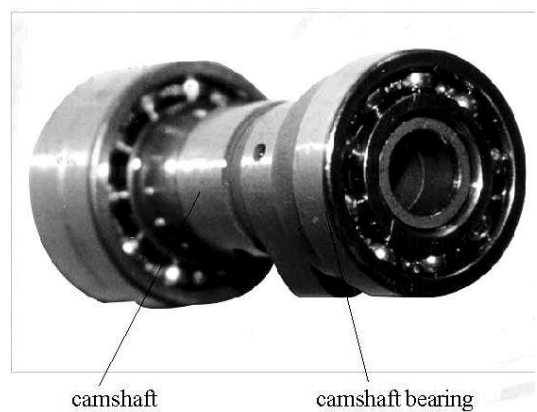

Check the gap of rocker arm shaft and rocker arm. Replace the rocker arm shaft and rocker arm if the gap is large.

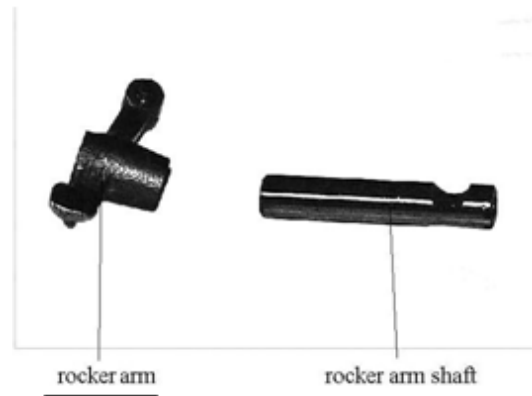

Check the external diameter of rocker arm using a micrometer. Replace the rocker arm shaft if the valve is beyond the maintenance limit valve.

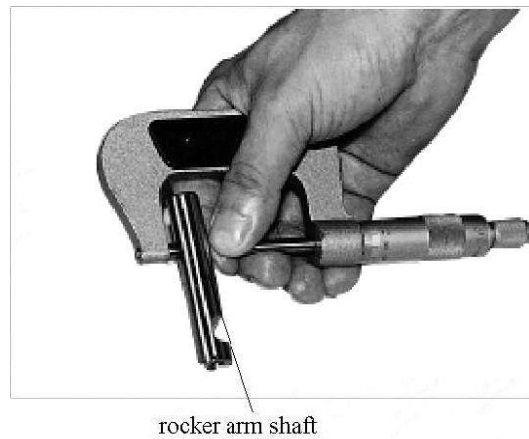

Remove the guide wheel of timing chain to inspect for wear and damage. Replace if necessary.

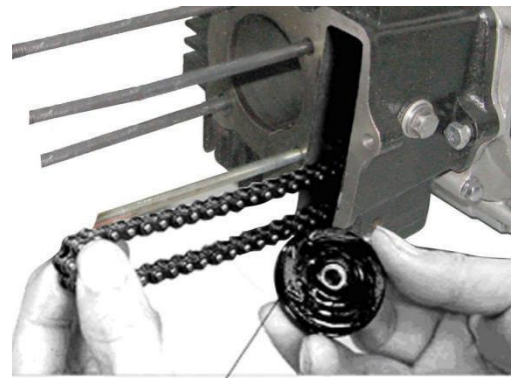

guide wheel

Remove the fixing bolt of timing tensioner and check the state. Replace if worn or if reuse is questionable.



bolt

Remove the timing tensioner arm to inspect for wear and damage. Replace if necessary.



timing tensioner

Remove the oil tube and spring and check the state. Replace if necessary.



oil tube

Remove the small timing chain and check the state. Replace if necessary.

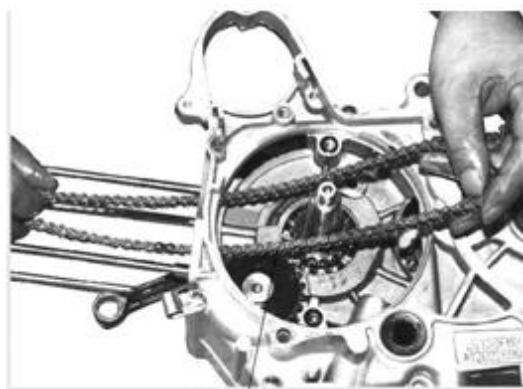

Adjust valve clearance as follows; Remove the valve cap and check the condition.

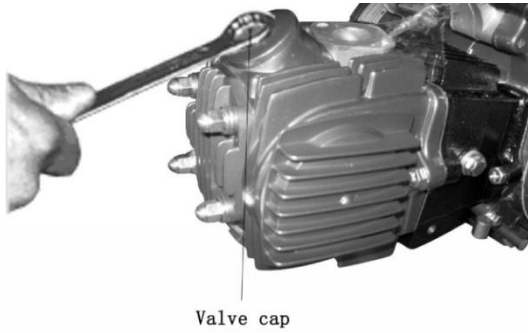

Adjust valve clearance of front cylinder. Turn magnetic rotor counterclockwise to make piston locate at top dead center and make T mark aimed to the mark of left crankcase cover.

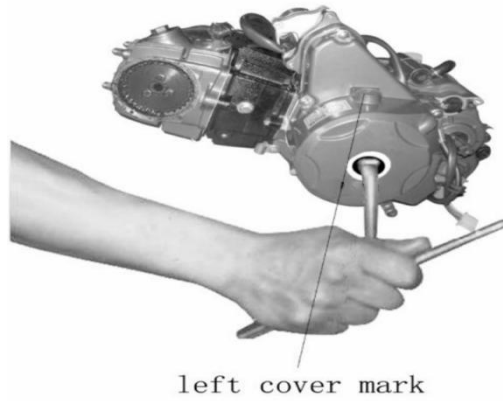

Check whether the O-mark on cam sprocket is aimed to the gap of cylinder head. Readjust if necessary.

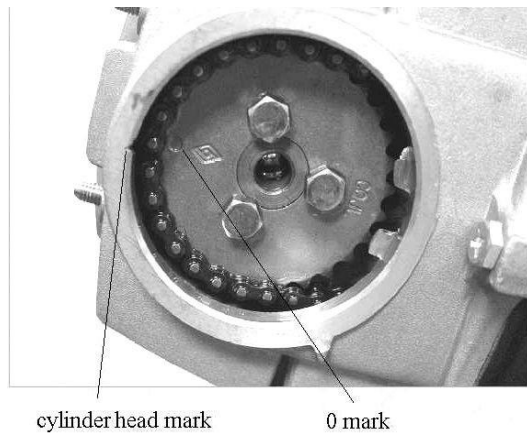

Set the valve clearance of rear cylinder to 0.05mm~0.06mm.

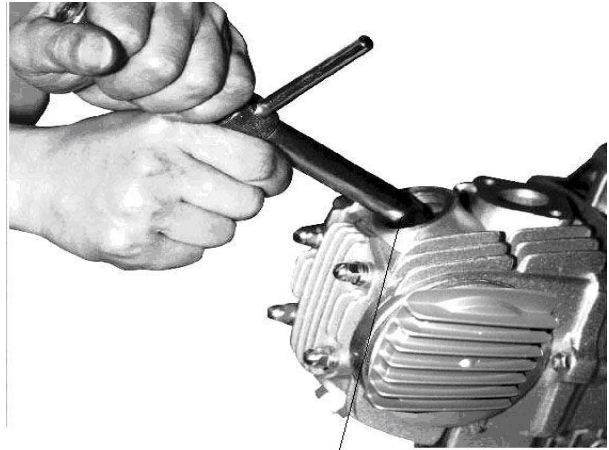

valve clearance adjustment

For the troubleshooting of engine distribution mechanism, please refer to the following table

Maintenance of Distribution Mechanism

Descriptions	Damage form	Trouble	Cause	Correction
--------------	-------------	---------	-------	------------

ZHEJIANG KAYO MOTOR CO., LTD.

Valve oil seal	The edge of valve oil seal is worn, age or damage.		Thick blue and white fume form the exhaust muffler pipe	Replace the complete set of valve oil seal
Camshaft	The cam is cover worn		Insufficient engine output	Replace the camshaft
	The bearing of the camshaft is over worn or damaged	The axial or radial clearance of the bearing is too wide. Ineffective bearing swiveling or abnormal sound during	Abnormal sound heard during camshaft transmission.	Replace he camshaft
Rocker arm	The working surface is scratched or over worn		Valve striking sound	Replace the rocker arm
	The rocker arm shaft hole is over worn	Big gap between the rocker arm and rocker arm shaft	Valve striking sound	Replace the rocker arm
	The rocker arm shaft is over worn	Big gap between the rocker arm and rocker arm shaft	Valve striking sound	Replace the rocker arm shaft
Valve	The valve clearance is too small	The valve is impossible to close completely	The engine starts hard or fails to start. Insufficient engine output; Engine speed changes during idle run	Readjust the valve clearance to 0.05~0.06mm
	The valve clearance is too big		Valve striking sound	Readjust the valve clearance to 0.05~0.06mm
	Carbon deposit on working surface	It is impossible to fit the valve and the valve seat tightly.	The engine starts hard or fails to start. Insufficient engine output; Engine speed changes during idle run	Remove the carbon deposit

ZHEJIANG KAYO MOTOR CO., LTD.

	The working surface is over worn or has pits, pock marks, ablation or damage	It is impossible to fit the valve and the valve seat tightly.	The engine starts hard or fails to start. Insufficient engine output; Engine speed changes during idle run	Replace the valve
	The valve stem is over worn	The fitting clearance between the valve stem and the valve guide is too wide	Sound of valve leakage, Thick blue and white fume form the exhaust muffler pipe	Replace the valve
	The valve stem is deformed	It is impossible to close the valve completely	The engine starts hard or fails to star	Replace the valve
Valve spring	The spring is ineffective or fractured	It is impossible to fit the valve and the valve seat tightly.	The engine starts hard or fails to star. Sound of the cylinder head	Replace the valve spring

5.6 Disassemble, assemble and maintain carburetor

(EPA model is not adjustable here)

Dismantle the fixing bolt of carburetor and circlip of air cleaner. Remove the carburetor. Remove and clean throttle cap

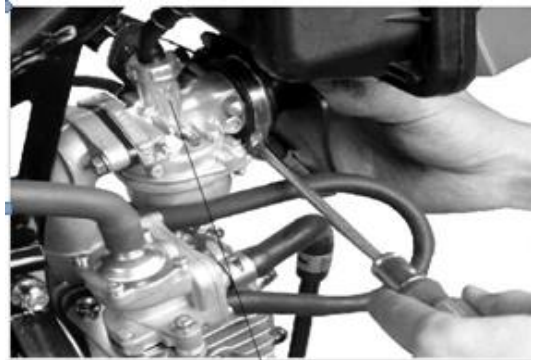

Clean the carburetor as follows: . Remove the dirt and clean inner oil way. Dismantle the fixing bolt of float chamber cap.

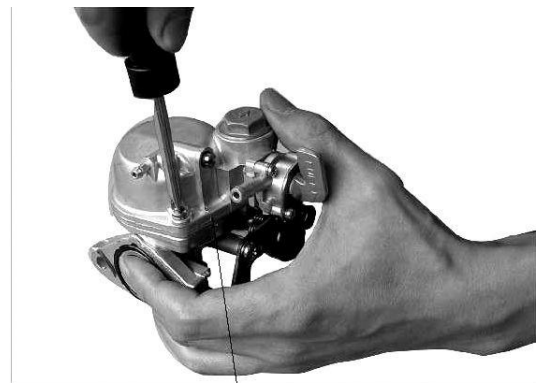

fixing bolt

Remove the float chamber cap. Remove the water and debris in the cap if necessary. Check the state of seal ring and replace if it is aging



Remove the float needle valve to inspect for wear and damage. Replace if necessary.

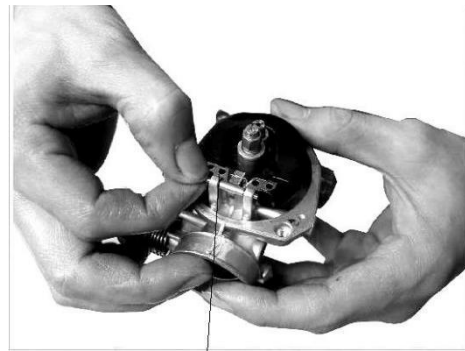

float needle valve

Remove the throttle and oil needle and check the condition replace if necessary.

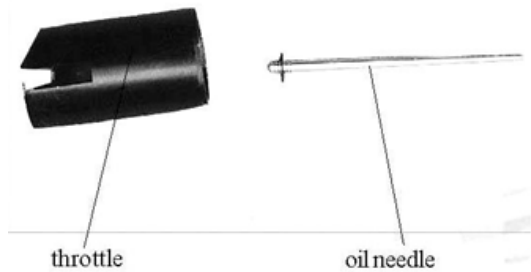

throttle

oil needle

Check the state of float case and replace as necessary. Adjust the height of float case by moving the float up or down.



seal ring



float case

Take out the main jet to check whether the jet hole is clogged. Clean if necessary.

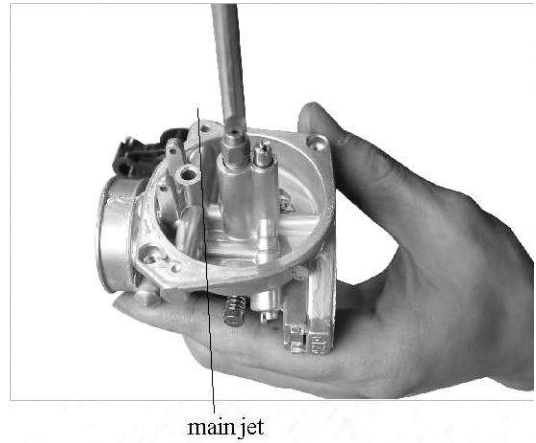

Remove the main nozzle to check whether small hole is clogged. Clean with compressed air if necessary.



Remove the idle jet and check for plugged. Clean the jet with compressed air if necessary

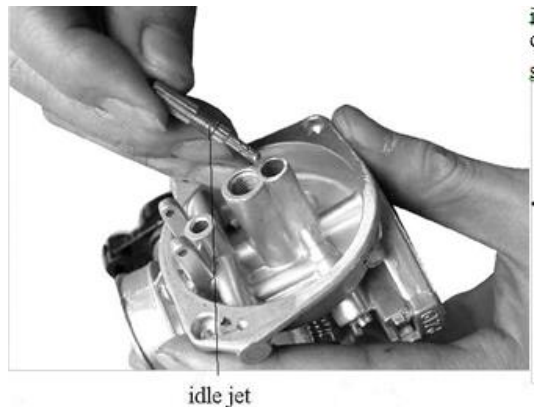

Dismantle the mixture adjustment screw and inspect for worn. Replace if necessary. Adjust mixture screw of carburetor as the following. Standard:

90

Tighten mixture screw, and turn it one
And a half turns clockwise

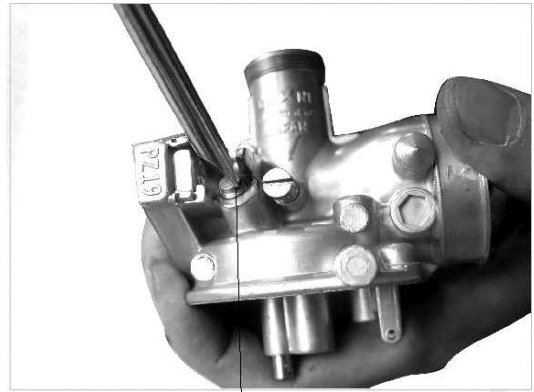

mixture screw

Measure height of float case to check whether it is distorted or there is oil in the case. If height is incorrect which indicates carburetor leaks or the oil supply is insufficient.

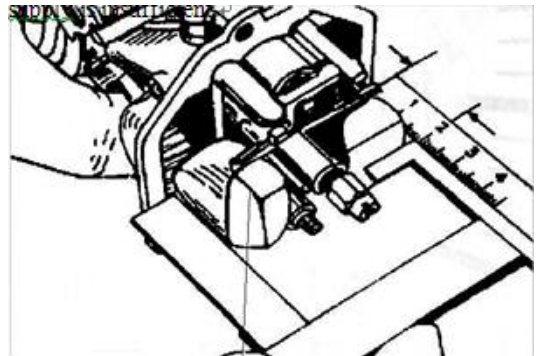

Adjust the oil needle to the third tier. If the clip rises, concentration of mixture becomes dilute and if falls it becomes thick.

5.7 Maintenance of Intake/Exhaust System

5.7.1 Disassemble, assemble and maintain intake system

Remove air filter clasp

Remove the air filter

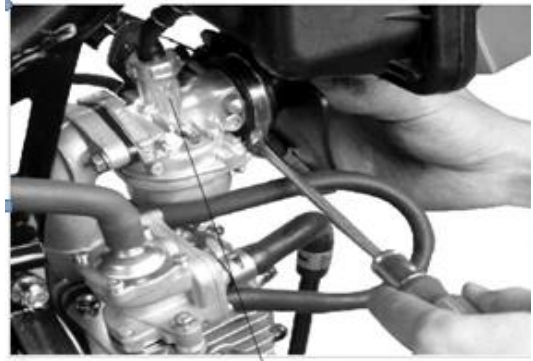

Remove the air filter to clean shell dust, and open the filter to clean.

As the filter is made of paper, so it can not be cleaned. Please replace the new air filter.

For the troubleshooting of the air cleaner, please refer to the following table.

Description	Damage form	Trouble	Cause	Correction
Air filter	Too much dust on the filter core	Engine starting difficulty or failure to start. Insufficient engine output; The engine performs poorly at idle. Excessive fuel consumption. Exhaust muffler tube	The engine starts hard or fails to start. Insufficient engine output; poor performance of engine during idle run. Excessive fuel consumption. The exhaust muffler pipe fumes strongly (black)	Clean the filter core
	The filter core is fractured or chapped.		Engine air suction noise is too loud	Replace the filter core

5.8 Disassemble, assemble and maintain exhaust system

Dismantle locknut of muffler

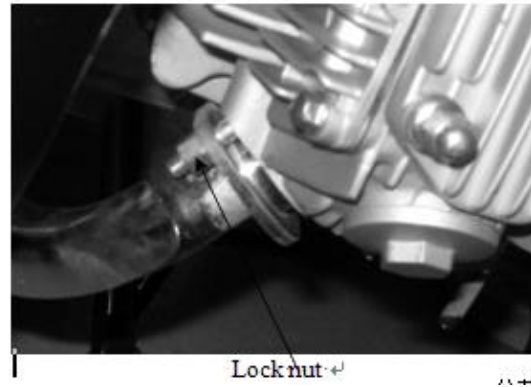

Dismantle suspension bolt of muffler to check whether the suspension support is damaged. Repair or or replace if necessary.



Remove the muffler to inspect for broken and damage. Replace or repair if necessary.



Remove the washer of muffler to inspect for damage. Replace if necessary.

Description	Damage form	Trouble	Cause	Correction
Exhaust pipe gasket	The gasket is broken	Exhaust pipe leakage	Engine exhaust noise is too loud.	Replace exhaust pipe gasket
Exhaust muffler	enclosure broken	The muffler enclosure is broken	Engine exhaust noise is too loud.	Replace exhaust muffler.



For the troubleshooting of the exhaust muffler, please refer to the following table.

Maintenance of Exhaust Muffler

5.9 Disassemble, assemble maintain the environmental protection valve

Inspect the locknut for tightness and tighten as necessary



Inspect the connecting circlip of air pump for tightness. Tighten if necessary.



mp
n or



Remove the secondary inlet air cleaner and inspect for wear and damage. Clean and replace if necessary.

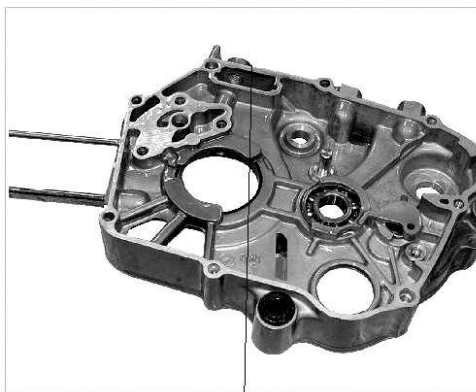

air cleaner

For the troubleshooting of environment protection valve, please refer to the following table.

Maintenance of environment protection valve

Parts	Damage form	Trouble	Cause	Correction
air pump	air pump broken or plugged	defective air pump	Emission fails to meet the standard	Replace
air cleaner	air cleaner damaged or plugged	defective air cleaner	Emission fails to meet the standard	Replace



ZHEJIANG KAYO MOTOR CO., LTD.

connecting hose	connecting hose get loose	noise is too big	Emission fails to meet the standard	Replace
Gasket	large noise from secondary inlet	air leaks form secondary inlet	Emission fails to meet the standard	Replace
muffler exhaust	too much carbon deposit on muffler exhaust	Poor combustion	Emission fails to meet the standard	Remove and clean

5.10 Disassemble, assemble, maintain and manage the electric starter

Remove the retaining bolt from the left crankcase cover



Remove the mounting bolt.
Remove the indicator and check for wear and damage. Replace if necessary.

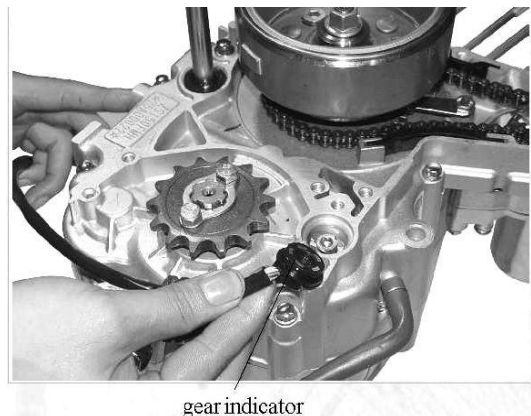

Remove the left crankcase cover



left crankcase cover

Remove washer and check condition. Replace if worn or reused.



gasket

Remove the magnetic stator fixing bolt and trigger bolt

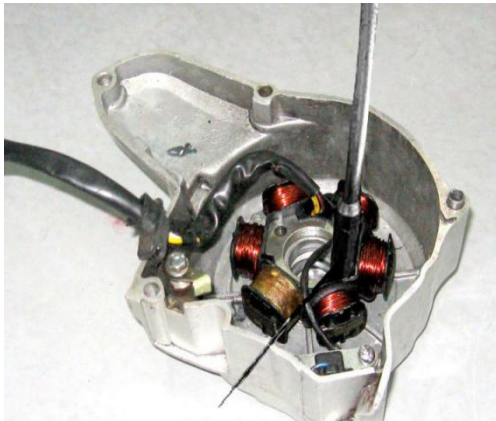

fixing bolt

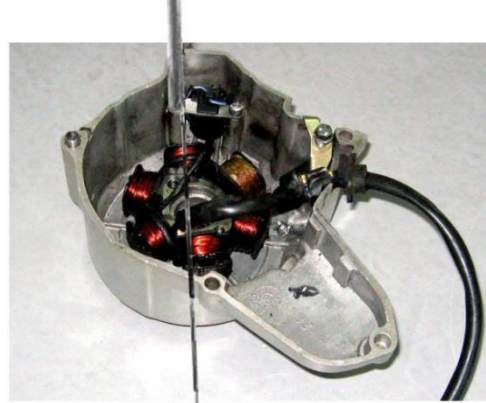

fixing bolt

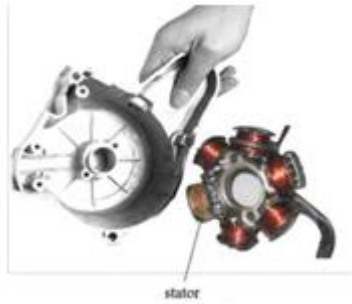

stator

Check stator state with multimeter. if worn or reused, replace the parts with new ones



stator

Remove rotor retaining nut



fixing nut

Remove the rotor with a special tool



Remove the rotor and check for demagnetization. Replace if necessary



Remove the overclutch retaining bolt.



fixing bolt

Remove clutch. Inspect clutch seats, rollers and springs for wear and damage. Replace if necessary.



Check for wear and damage of drive sprocket and drive gear and replace if necessary

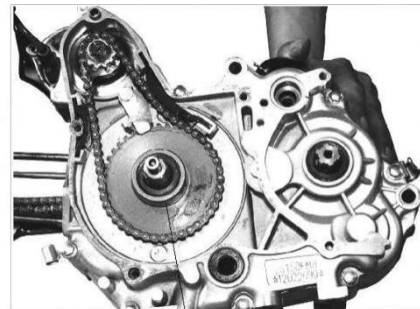

driving gear

Remove the sprocket wheel press board



pressing plate

Remove the tension band of the clutch and check its condition. If the tension belt is found to be worn or has problems , the tension belt should be replaced.

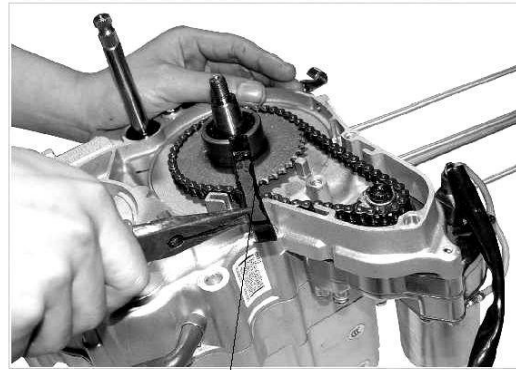

tension strip

Remove the snap ring of the starting motor sprocket

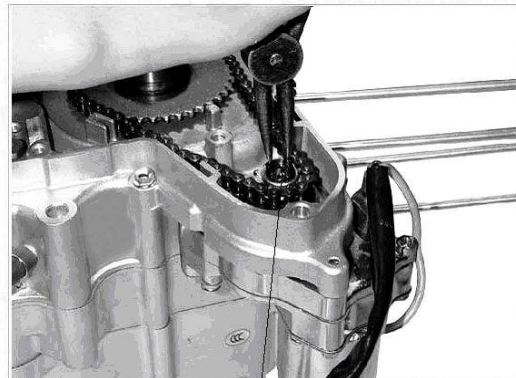

sprocket circlip

Remove the drive sprocket and chain

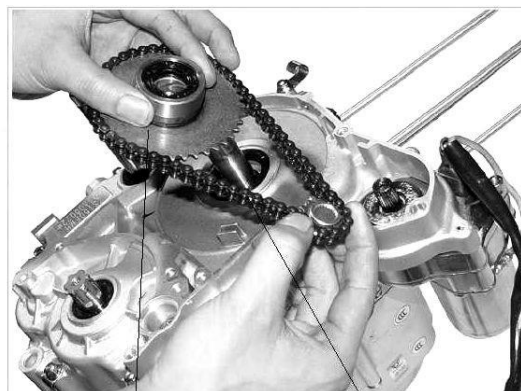

driving sprocket

driving chain

Remove starter motor retaining bolts.

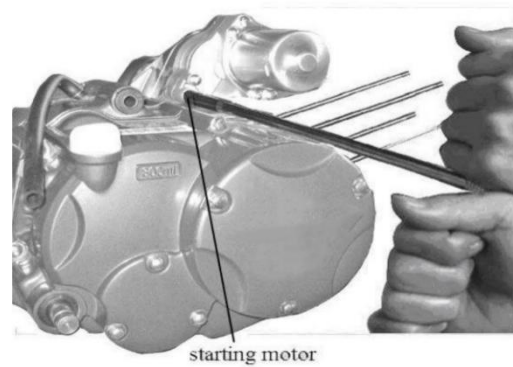

Remove the starting motor.

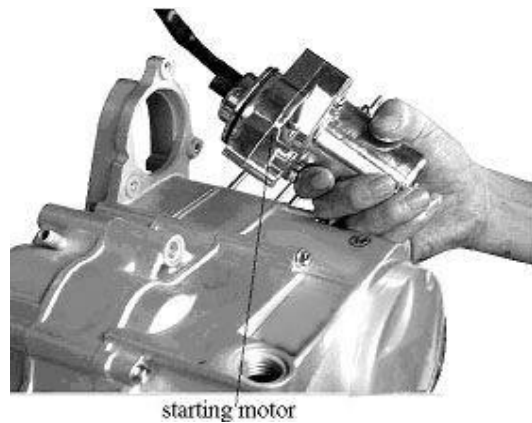

are damaged. Replace if necessary.

Check whether the starter windings

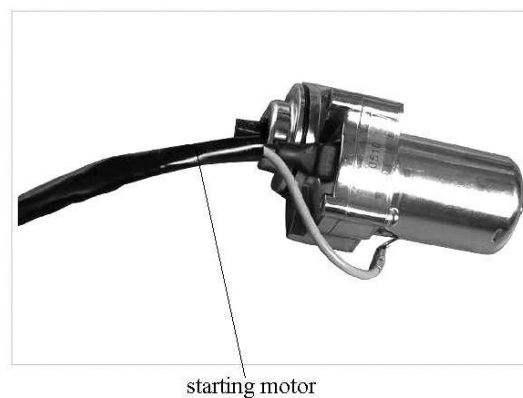

Remove oil separation disc and check condition. Replace if necessary.

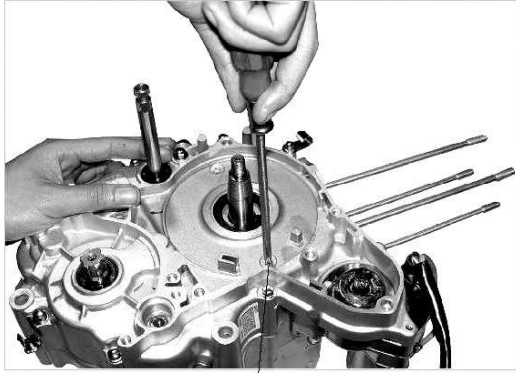

fixing
bolt

Check whether the oil seal is worn.
Replace if necessary.

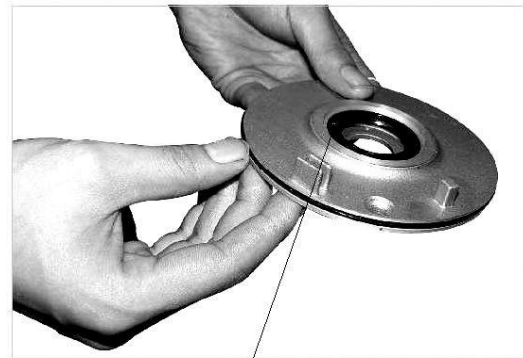

oil seal

Remove the seal ring. Check the
Condition of the oil seal ring
and replace it is worn.

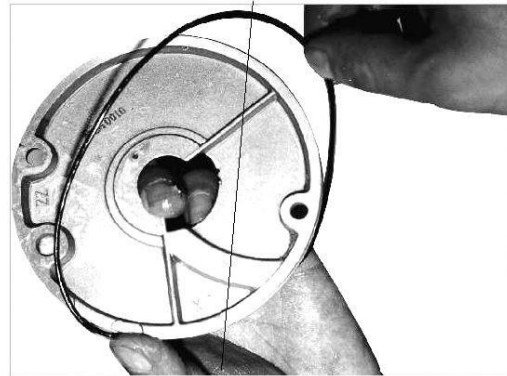

For the troubleshooting of engine electric starter, please refer to the following table.

Maintenance of Electric Starter

ZHEJIANG KAYO MOTOR CO., LTD.

Description	Damage form	Trouble	Cause	Correction
Starter motor	Carbon brush is over worn. The carbon brush spring is		Starter motor has insufficient rotation force or it is out of work.	Replace carbon brush
	fractured or has insufficient elastic force.		Starter motor has insufficient rotation force	Replace carbon brush spring
	Armature commutator surface is fouled.		Starter motor has insufficient rotation force	Clean the commutator surface
	Armature commutator surface is spotted, burnt or damaged.		Starter motor has insufficient rotation force.	Polish the surface against The Commentator with fine abrasive Paper. Make the cut on the mica Plate between each commutator
	Armature commutator surface is ablation or over worn.		Starter motor has insufficient rotation force or is out of work.	Replace starter motor

Complete vehicle circuit diagram

